

**PARTS LIST  
AND  
MAINTENANCE  
MANUAL  
FOR  
1/4 TON  
2 WHEEL TRAILER  
BUILT FOR  
U. S. GOVERNMENT  
MODEL T3**

Contract Number  
W-2425-qm-672

U. S. A. Reg. Numbers  
0253934 to 0277083

"This Publication supersedes TM-10-1281,  
Dated July 15, 1942"

Parts are designated in this book under both Willys and Bantam part numbers because all parts are interchangeable with vehicles produced by Willys-Overland Motors, Inc.

Contract W-2425-qm-673      Model MBT

U. S. A. Registration Numbers  
0212994 to 0244966  
TM-10-1230

**AMERICAN BANTAM  
CAR COMPANY**

BUTLER, PENNSYLVANIA, U. S. A.

Copyright 1942

**TM-10-1281**

September 30, 1942

INDEX		
	*Section	Page
Driver's Instructions		5
Lubrication and Inspection		6
Electrical	0600	9
Axle	1000	11
Brakes	1200	13
Wheels, Hubs and Drums	1300	15
Frame	1500	17
Springs and Shock Absorbers	1600	19
Body	1800	23
Parts List Alphabetical		29
Parts List Government Group		31
Parts List Numerical & Prices		36

\* These numbers refer to Parts Group Classifications in Parts List.

## **F O R E W O R D**

This Vehicle has been thoroughly inspected and like any other piece of machinery, to maintain it in proper operating condition, it should be lubricated and receive periodic systematic inspections as outlined in this Manual.

All parts in this vehicle are completely interchangeable with those manufactured by Willys-Overland Motors, Inc., under the contract listed on the title page. Both Willys and Bantam part numbers are therefore listed.

In the following pages we have described how to take care of this unit and handle it in such a way that it will give maximum service and dependable performance.

In the forepart of this Manual will be found complete instructions relative to Driver's Instructions, Lubrication and Inspection. In the back of the Manual will be found the Parts Section.

In the Maintenance and Repair Section will be found instructions which will enable one to make proper adjustments and repairs.

**See Index on title page; bend back edge of pages to find Section desired**

**Read and follow instructions carefully**

**THE AMERICAN BANTAM CAR COMPANY**

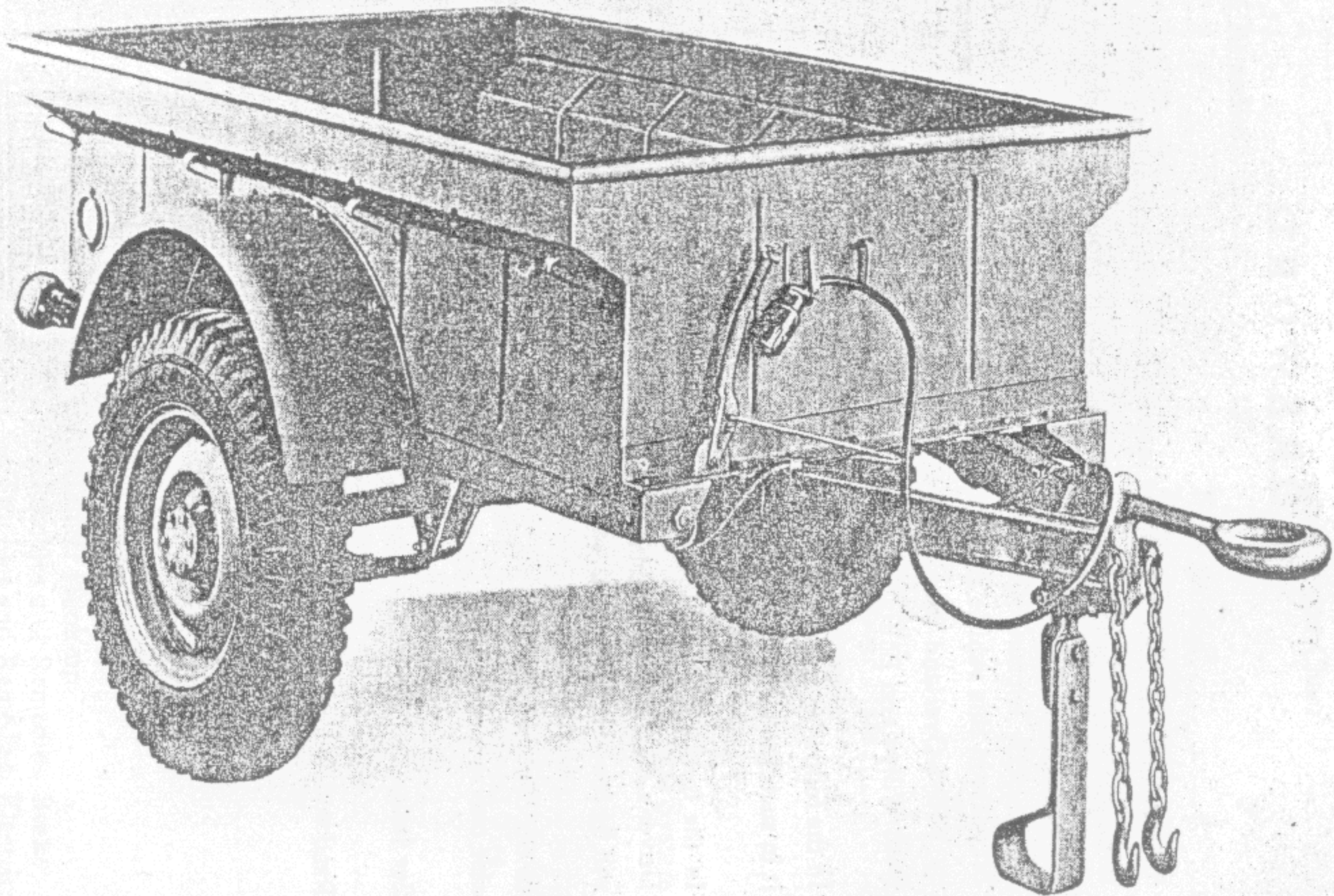

1/4 TON TWO WHEEL GOVERNMENT TRAILER

## GENERAL DATA

Type.....	2 Wheel	
<b>Body Dimensions</b>		
Inside Length.....	72"	1828.8 mm
Inside Width.....	38"	965.2 mm
Inside Depth of Side Vertical Wall.....	11"	279.4 mm
Inside Depth of Overall.....	18"	457.2 mm
Inside Depth of Front and Rear Panels.....	18"	457.2 mm
Width of Body at Top.....	46"	1168.4 mm
Capacity—Cubic Feet.....	30.4	.861 Cubic Meters
Capacity—Pounds.....	500 lbs.	226.8 Kgs.
Tire Size (Combat Tires) Inches.....	6.00 x 16	
Road Clearance.....	12½"	317.5 mm
Tread.....	49"	1244.6 mm
<b>Overall Dimensions</b>		
Length.....	108½"	2755.9 mm
Width.....	56"	1422.4 mm
Height (Loaded).....	40"	1016.0 mm
<b>Weight—</b>		
Maximum Pay Load (Capacity).....	500 lbs.	226.8 Kgs.
Shipping and Road.....	550 lbs.	249.5 Kgs.
Gross.....	1050 lbs.	476.3 Kgs.
Floating Water Line above Floor.....	12"	3048.8 mm

### LAMP BULBS

Left Tail Lamp Bulb—Upper (1).....	21-3 Cp. DC No. 1154
Left Tail Lamp Bulb—Lower (1).....	3 Cp. SC No. 63
Right Tail Lamp Bulb—(2).....	3 Cp. SC No. 63

### IDENTIFICATION

TRAILER 2 WHEELS ¼ TON

SUPPLY ARM OR SERVICE  
 MAINTAINING VEHICLE-ORDNANCE DEPARTMENT.  
 MAKE AND MODEL **BANTAM-T 3**  
 SERIAL NUMBER   
 GROSS WEIGHT   
 MAXIMUM PAYLOAD  1050 LBS.  
 MAXIMUM SPEED  500 LBS.  
 CUBIC CONTENT  65 M.P.H.  
 DATE OF DELIVERY  30.4 CU.FT.

---

PUBLICATIONS APPLYING TO THIS TRAILER  
 PARTS LISTS T/MIO-1281  
 MAINTENANCE MANUAL T/MIO-1281

BANTAM

AMERICAN BANTAM CAR CO.  
 BUTLER, PA.

Manufacturer's Serial Number & Nomenclature plate located on front of body at left upper corner.



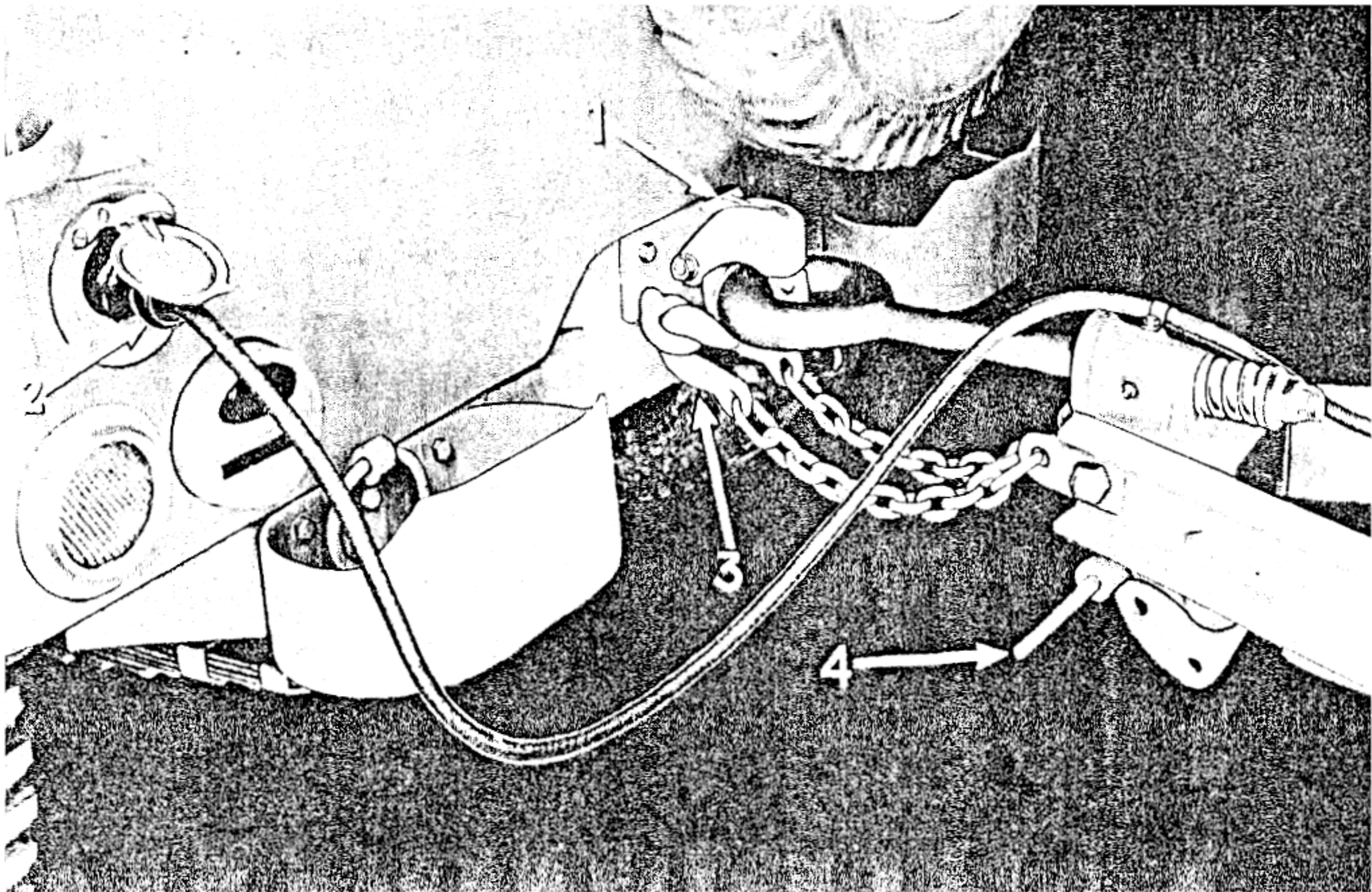

FIG. 1—TRAILER HOOK-UP



## DRIVER'S INSTRUCTIONS

In the use of a two wheel trailer it is important to properly distribute the load for balance on the axle. Tires should be inflated to 30 pounds pressure. Due care should be exercised when coupling or uncoupling the trailer from the vehicle so that it will not get out of control. Set the hand brake when parking the trailer.

To couple up trailer, lift up the pintle hook lock on the truck and raise the latch, Fig. 1, No. 1, raise the trailer and place trailer draw bar or Lunette Eye in hook. Close the pintle hook and be sure that the lock is down in place.

Next hook up the safety chains. Do not cross them. Insert the hooks from the under side of the eye, Fig. 1, No. 3, then the hooks will not jump out in going over rough ground. Connect up the electrical system by raising the cover on the coupling socket in the left rear side of the truck body, Fig. 1, No. 2 turning the cable plug positioning lug to line up with groove in socket and push the plug well forward into the socket, Fig. 2.

Pull out on the support leg plunger, Fig. 1, No. 4 and raise leg to horizontal position.

Use one man to move vehicle and another to handle the hook-up when the trailer is heavily loaded or there is a possibility of the trailer getting out of control. In such instances back the vehicle to the trailer and release the brakes as the last operation.

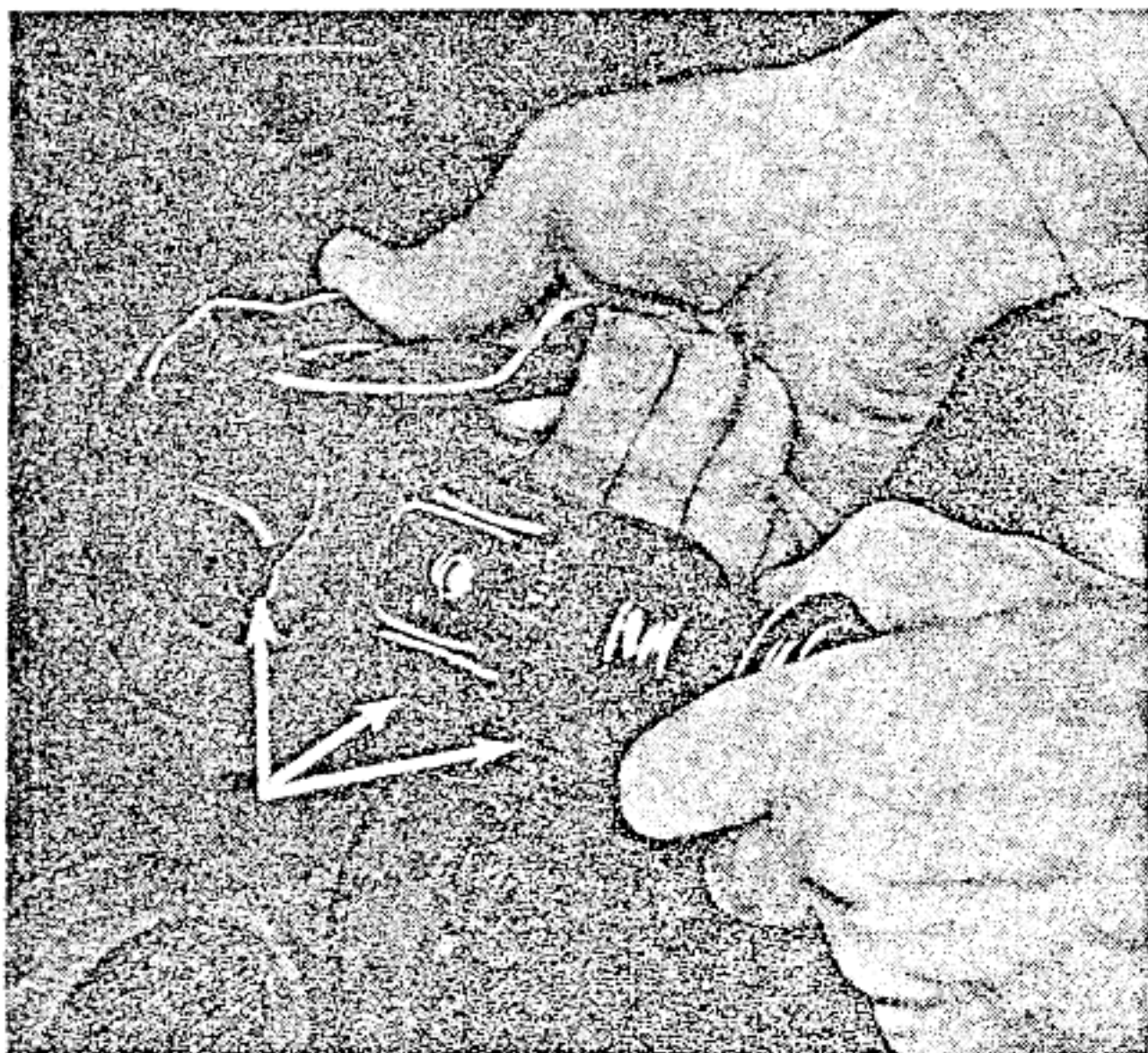

FIG. 2—SOCKET PLUG

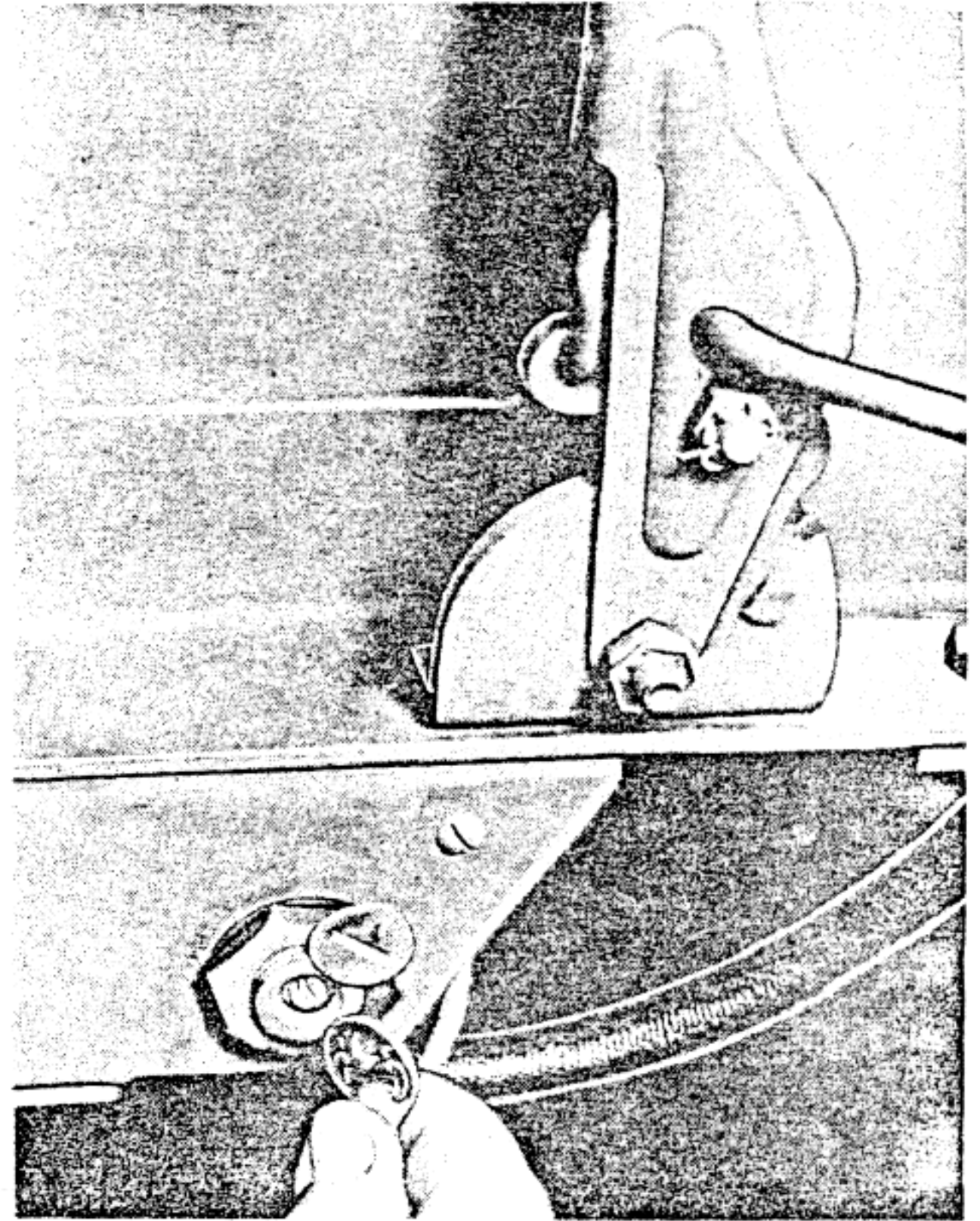

FIG. 3—LIGHT SWITCH

To uncouple trailer, pull cable plug out of socket, unhook chains and hook over chain attachment link on trailer, drop support leg by pulling out on plunger handle. Be sure support leg locks in down position. Unlock pintle hook and uncouple trailer.

Light switch, Fig. 3—When the trailer is coupled to the truck, tail and stop lights can be controlled by operation of the lighting system or brake application in driving the vehicle. When the main lighting switch is changed to blackout position it is necessary to turn the switch provided on the trailer below the hand brake lever, otherwise the trailer service tail and stop lights will continue to function. Push aside the cover on the switch, and, using the car key or a screw driver, turn the switch ¼ turn to the right side of the trailer for blackout lights and to the left for service lights.

**DO NOT FORGET TO RELEASE TRAILER BRAKE BEFORE ROLLING.**

The body is waterproof and designed so the vehicle will float carrying a load of 500 pounds. The loaded water line is 12 inches above the floor.

A tarpaulin cover is provided and is easily installed by taking a half hitch in the ropes around the hooks.



# LUBRICATION AND SERVICING

- 1—Spring Shackle(2)  
2 hydraulic fittings  
Pressure gun  
Chassis grease

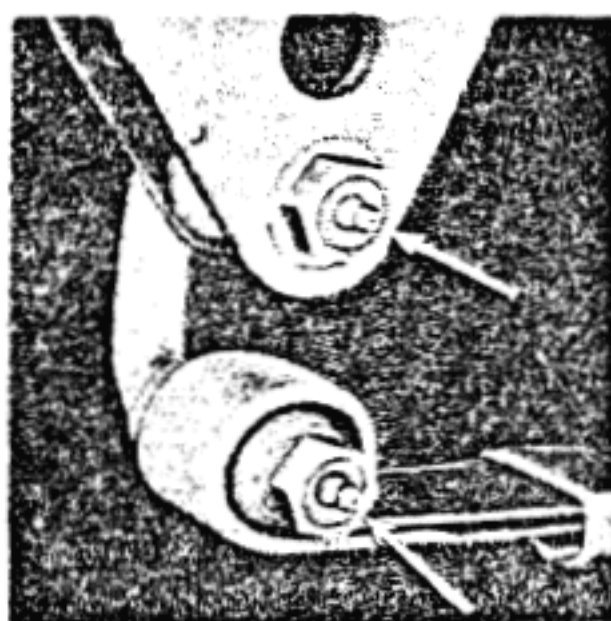

- 2—Spring Bolt (2)  
1 hydraulic fitting  
Pressure gun  
Chassis grease

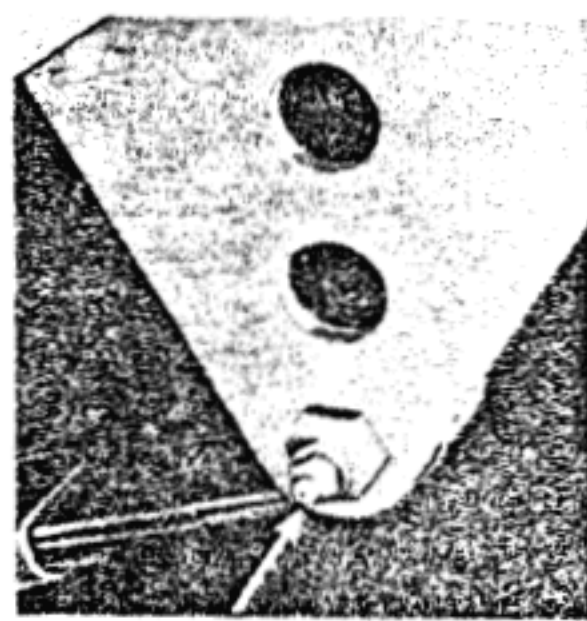

- 10—Lever Shaft  
Hand brake  
Oil can  
Engine oil

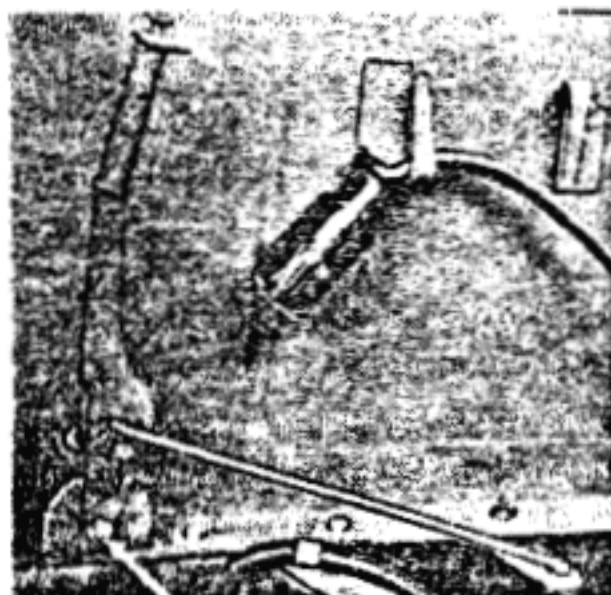

- 19—Wheel Bearings  
(2)  
Remove and repack  
Chassis grease

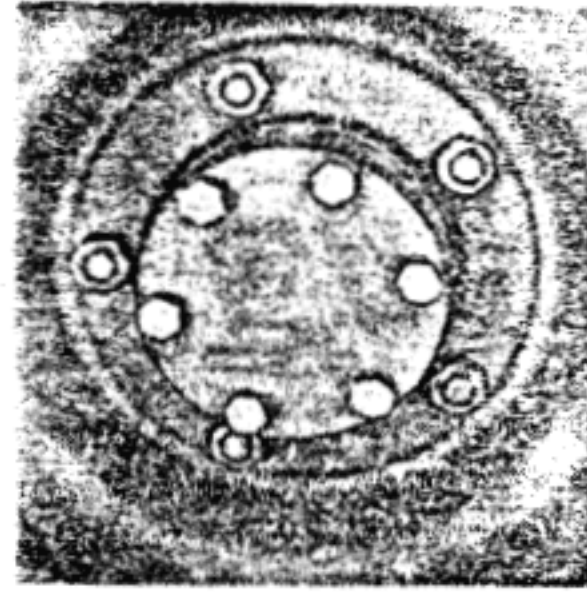

- 21—Linkage  
All pins and rods  
Oil can  
Engine oil



- 54—Flexible Cable-  
Brake (2)  
Dismantle and  
grease by hand  
Chassis grease

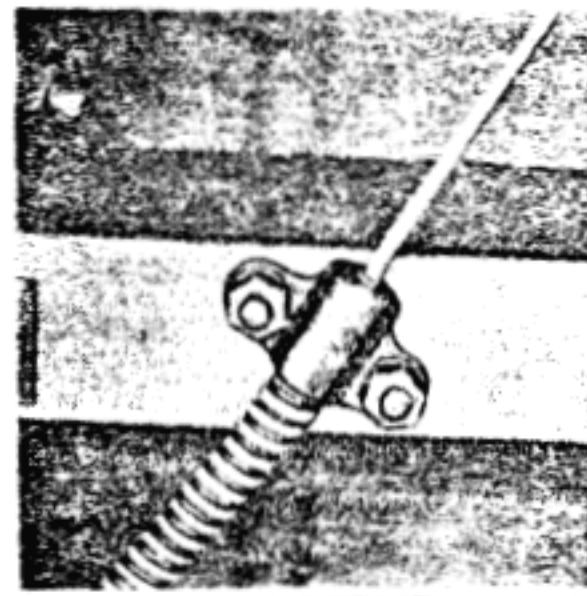

Lubrication of any vehicle is important to prevent damage to moving parts. To secure maximum useful service from the vehicle, it is important to use the proper grade of lubricant and apply it in accordance with a definite schedule.

The chart in this section should be referred to for instructions on mileage of application, grade and quantity of lubricant required for all parts of the vehicle.

Standardized Army item numbers are used above and on the Lubrication Chart to indicate points to be lubricated. Those numbers not shown are for items not used on this trailer.

Under normal operating conditions the hub bearings require lubrication approximately every 6,000 miles of continuous service or in the Spring and Fall if trailer is used only intermittently. The hubs and bearings should be removed and thoroughly washed in suitable cleaning fluid. Inspect for pitted races and rollers, renew if necessary and repack with grease. Lightly pack grease in the wheel hubs. See "Wheels" Section, Page 15, concerning bearing adjustment.

Should the brakes fail to release due to the cables sticking in the conduits, the front brackets should

- 66—Swivel-Lunette  
Eye  
1 hydraulic fitting  
Pressure gun  
Chassis grease

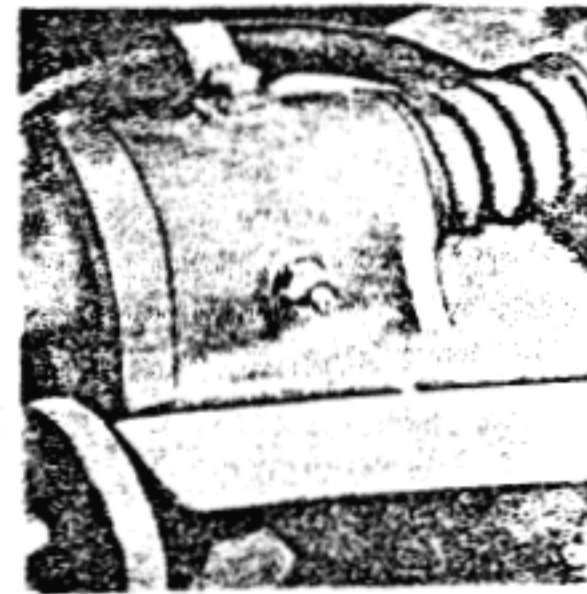

- 82—Pivot-Landing  
Gear and Lock  
Oil Can  
Engine Oil

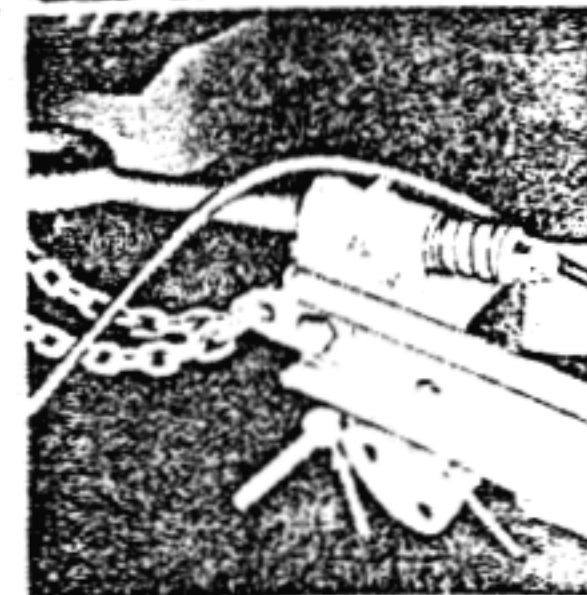

be removed from the frame and the conduits loosened at the brake backing plates. Clean the brake cables ahead of the conduits and slide conduits forward after which clean the cables and lubricate, then replace conduits. Be sure conduits fit into front brackets; check brake operation and adjust if necessary.

**LUBRICATION CHART**  
¼ Ton 2 Wheel Trailer Chassis  
Mechanical Brakes

Make Willys  
Model MBT

Make Bantam  
Model T3

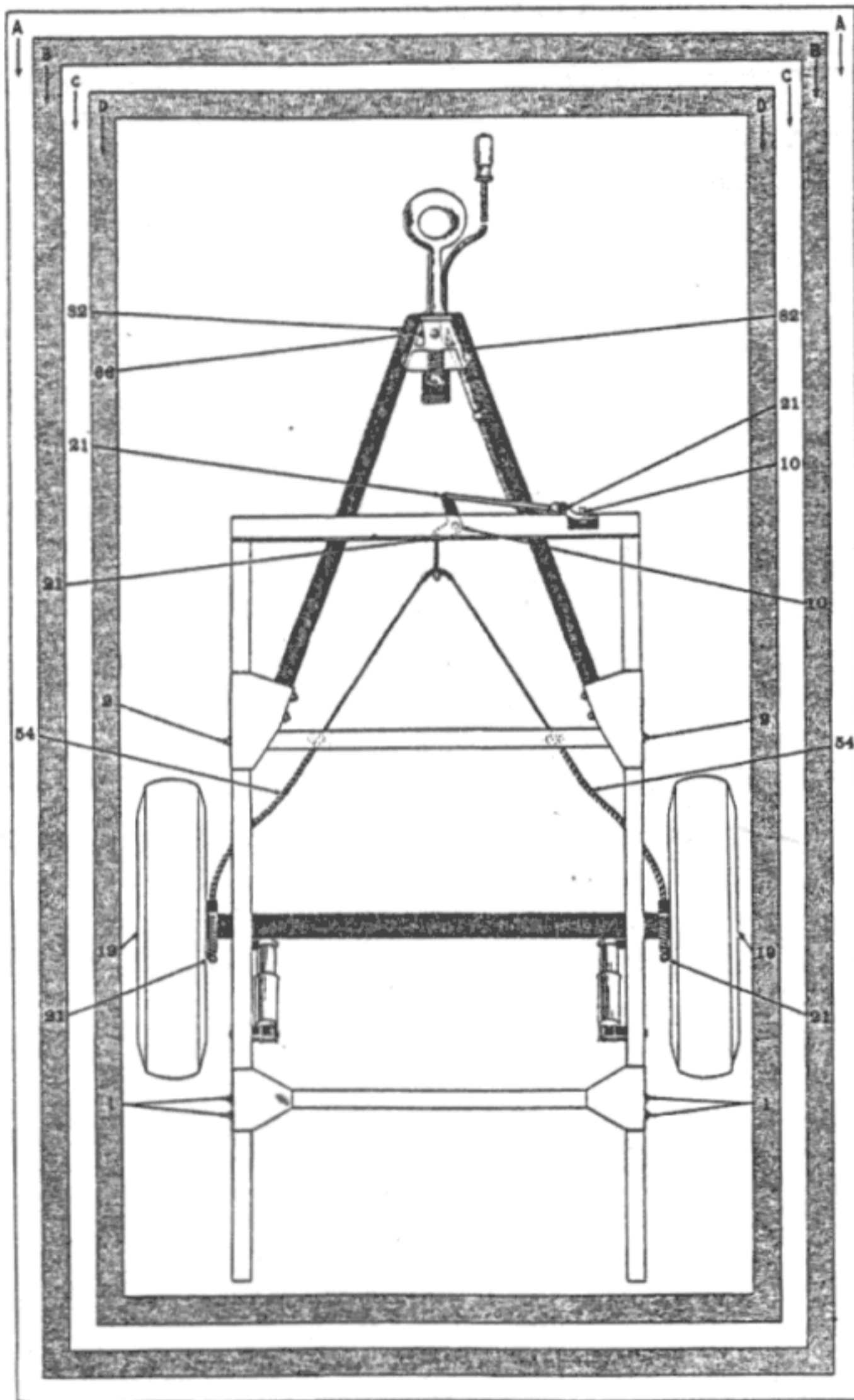
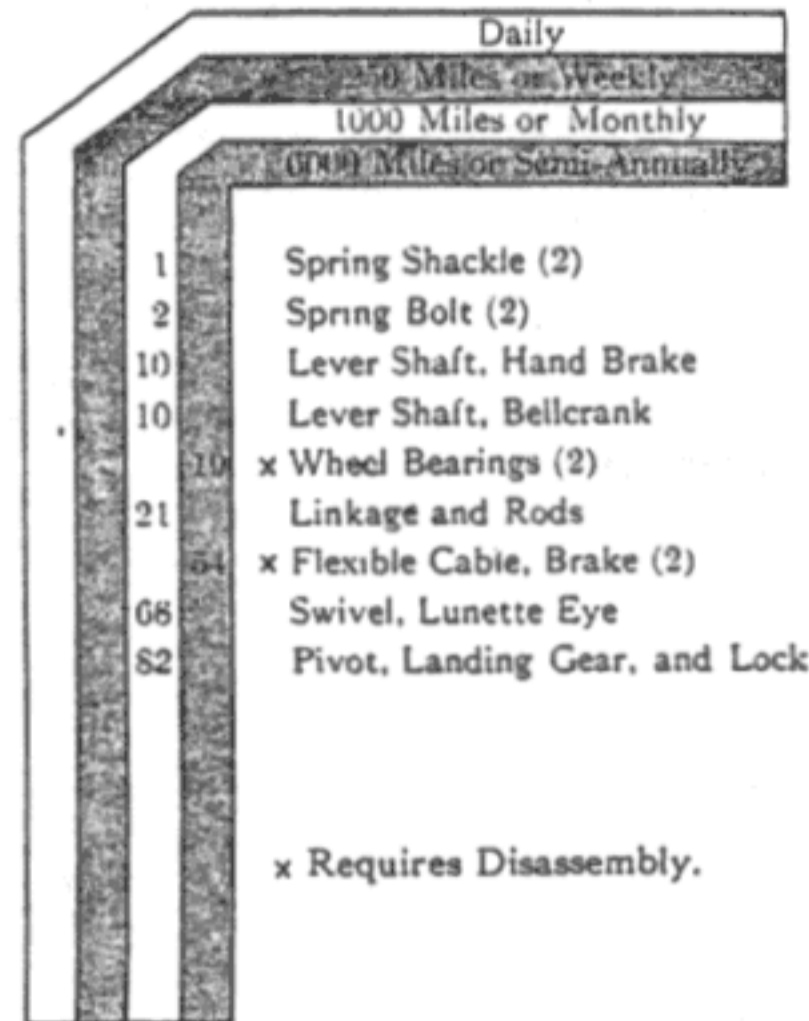

FIG. 4—LUBRICATION CHART



**TOOLS**

- Cleaning Rag
- Wheel Bearing Nut Wrench
- Screw Driver
- Hammer

**INSTRUCTIONS**

Clean and lubricate all points in the order indicated, except those which require disassembly. Disassemble as separately instructed.

**BELOW VEHICLE**

- Frame A—Chassis Grease
- Frame B—Engine Oil

**ABOVE VEHICLE**

- Frame C—Engine Oil
- Frame D—Chassis Grease

**PREDOMINATING TEMPERATURE**

	Above and 32° F.	Between 32° F. and 0° F.	Below 0° F.
Chassis Grease . . . . .	#1	#1	#1
Engine Oil . . . . .	30	10	10

Chassis grease No. 1 is U. S. Army Specification No. 2-107  
 Engine Oil No. 30 is U. S. Army Specification No. 2-104A, SAE 30  
 Engine Oil No. 10 is U. S. Army Specification No. 2-104A, SAE 10



## PREVENTATIVE MAINTENANCE

The importance of regular inspection cannot be over-emphasized. Making adjustments, tightening bolts, nuts and wiring connections when needed, will go far towards avoiding trouble and delay on the road and uphold the high standards of reliability built into the vehicle by the Manufacturer.

The following recommendations are made considering the service that the vehicle must render on maneuvers.

After completing maneuvers involving operations in swamps and streams inspect for water in wheel bearings and electrical system.

OPERATION	Daily by Driver	Each 1000 Miles	Each 6000 Miles	12,000
<b>Axle</b>				
Check Axle Alignment (After hard maneuvers or excessive loads) .....		X		
Check Wheel Bearings for Looseness and Wear.....		X		
Inspect for Oil Leaks.....		X		
<b>Body</b>				
Check Bolts in Body Side Rails.....		X		
<b>Brakes</b>				
Makes Visual Inspection of Brake Cable and Linkage.....	X			
Remove Wheels; inspect brake lining.....			X	
Check Brake Pull Back Springs.....			X	
Test Hand Brake; adjust if necessary.....	X			
<b>Wiring, Lights &amp; Switches</b>				
Inspect all Connections.....		X		
Inspect for Chafed or Broken Wires.....		X		
Inspect Retaining Clips and Grommets.....		X		
Check Operation of Lights.....	X			
<b>Lubrication</b>				
Refer to Lubrication Chart.....	X	X	X	X
<b>Springs</b>				
Inspect Spring Clips to Axle for Tightness.....		X		
Inspect Spring Shackles and Bushings.....		X		
Check condition of Springs.....		X		
<b>Shock Absorbers</b>				
Inspect Mounting Bushings, replace when necessary.....		X		
Inspect Mounting Brackets.....		X		
Check for Control; adjust or replace.....				X
<b>Wheels and Tires</b>				
Check Tire Pressures.....	X			
Tighten Wheel Hub Bolt Nuts.....			X	
Remove Wheel Bearings, inspect, repack and adjust.....			X	
Check Tire Wear.....		X		

# ELECTRICAL SYSTEM

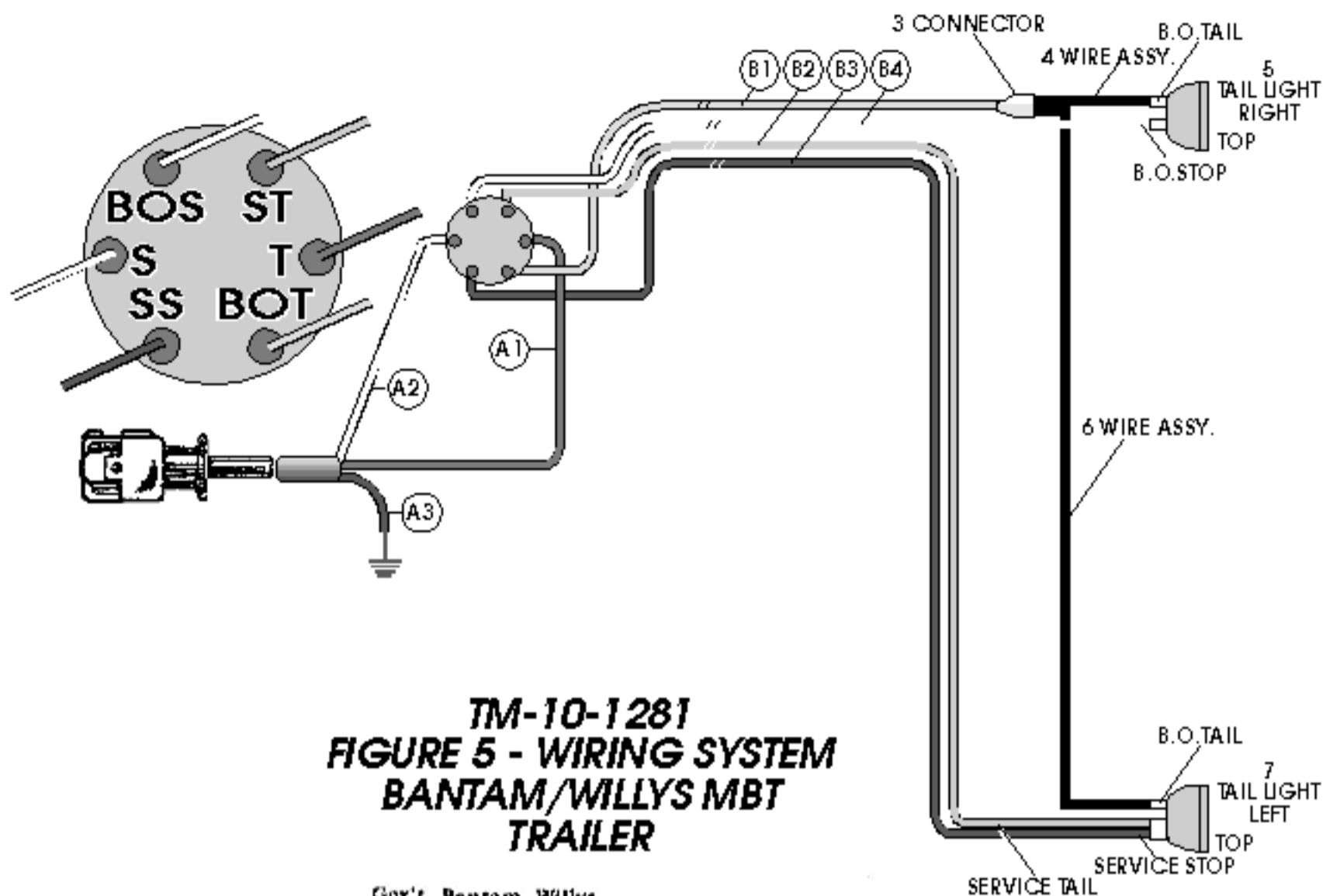

**TM-10-1281**  
**FIGURE 5 - WIRING SYSTEM**  
**BANTAM/WILLYS MBT**  
**TRAILER**

Item No.	Gov't Group No.	Bantam Part No.	Willys Part No.	Name
1	0606	14276	A-6021	Blackout Switch
2	0606	14317	A-6387	Coupling Socket Plug & Cable Assem.
3	0606	14356	635985	Connector (3-Way)
4	0606	14318	A-6340	Cable, Right (Connector to Blackout Tail Light)
5	0608	R-11540	A-1065	Tail Light Assembly—Right
6	0606	14342	A-6339	Cable, Left (Connector to Blackout Tail Light)
7	0608	R-11544	A-1064	Tail Light Assembly—Left

The wiring system Fig. 5, shows the general arrangement of all electrical circuits together with the units in relation to the position in which they are found. When inserting the socket plug in the back of the truck it is necessary to turn the lugs on the plug so that they line up with the slot in the socket. See Fig. 3.

Regular inspection of all connections avoids failures in the electrical system. To facilitate wiring, the terminals on the socket plug and light switch are marked. When tracing any one particular circuit in the wiring diagram, refer to the Wiring Chart below for color of wire and tracer.

## COUPLING SOCKET CABLE ASSEMBLY

No.	Color	Name
A-1	Brown	Coupling Socket Terminal "TL" to Trailer Switch Terminal "T"—Cable
A-2	White	Coupling Socket Terminal "SL" to Trailer Switch Terminal "S"—Cable
A-3	Red	Coupling Socket Terminal "GR" to Trailer Ground—Cable

## TRAILER WIRING HARNESS EXTENSION

No.	Color	Name
B-1	Yellow with 2 Black Tracers	Trailer Switch "BOT" to Blackout Tail Light Connector—Cable
B-2	Blue with 2 White Tracers	Trailer Switch "ST" to Service Tail Light—Cable
B-3	Red with 2 White Tracers	Trailer Switch "SS" to Service Stop Light—Cable
B-4	White with 2 Black Tracers	Trailer Switch "BOS" to Blackout Stop Light—Cable, Right side



## OPERATION OF CAR AND TRAILER LIGHTING SYSTEM

Truck Main Light Switch Position	Foot Brake Off or On	Truck Tail Lights	Trailer Tail Light With Trailer Switch In Service Position	Trailer Tail Light With Trailer Switch Blackout Position
Off	Off	Off	Off	Off
Stoplight	Off	Off	Off	Off
Stoplight	On	Service Stop	Service Stop	Blackout Stop
Service Head	Off	Service Tail	Service Tail	Blackout Tail
Service Head	On	Service Tail & Service Stop	Service Tail & Service Stop	Blackout Tail & Blackout Stop
Blackout Head	Off	Blackout Tail	Service Tail	Blackout Tail
Blackout Head	On	Blackout Tail & Blackout Stop	Service Tail & Service Stop	Blackout Tail & Blackout Stop

The trailer lighting system operates in connection with the truck except in changing over from service to blackout or vice versa. In this case it is necessary to operate the light switch on the trailer located just below the hand brake lever. Push the switch cover aside, use a screw driver or the handle end of the car key to turn the switch ¼ turn to the right side of the trailer for blackout lights and to the left for service lights. When the truck main light switch is in position for the lights to operate, the stop lights function as the brakes are applied by the driver. Keep the trailer light switch turned to the left side of the trailer (Service Position), except when Blackout is desired.

The tail and stop lamps, Fig. 6, consist of two separately sealed units placed in the Lamp Body.

The upper left rear stop light, or service unit is a combination tail and stop light and consists of lens, gasket, reflector and a 21-3 C.P. Bulb. The upper right rear is a blackout stop light and uses a 3 C.P. bulb. The lower unit in each lamp is the blackout tail light. These bulbs, lenses and reflectors are sealed units. When a filament burns out, the bulb and lens unit must be replaced.

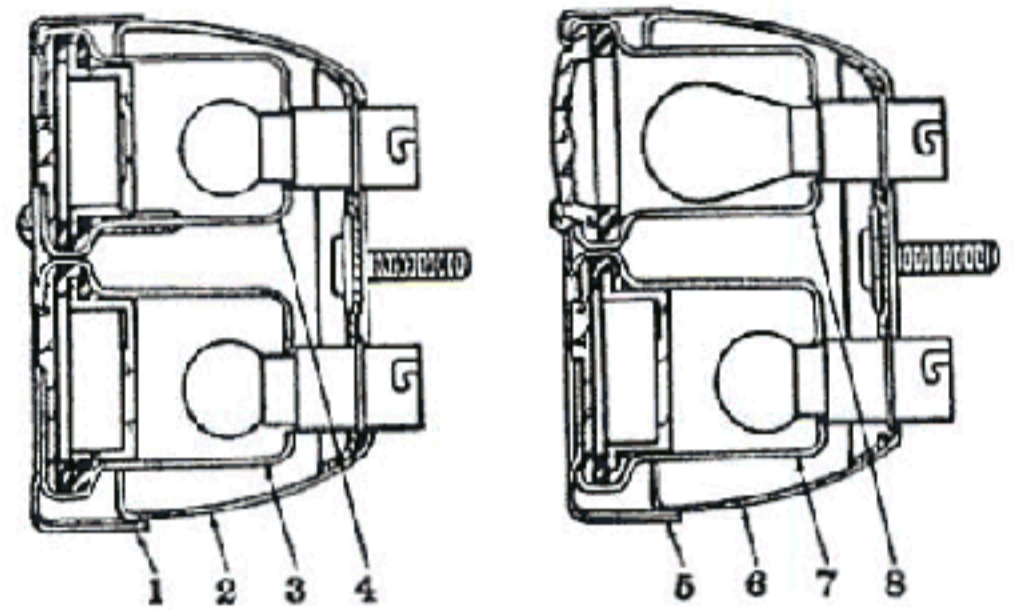

FIG. 6—TAIL LAMPS

Item No.	Gov't No.	Willys Part No.	Bantam Part No.	Name
1	0608	A-1079	R-21380	Door—Tail and Stop Lamp Assembly (Right)
2	0608	A-1073	R-21379	Housing Sub-Assembly
3	0608	A-1075	R-21357	Lower Tail Lamp Unit Assembly
4	0608	A-1078	R-21356	Upper Stop Lamp Unit Assembly—Tail and Stop Lamp Assembly (Right)
5	0608	A-1076	R-21381	Door—Tail and Stop Lamp Assembly (Left)
6	0608	A-1073	R-21379	Housing Sub-Assembly
7	0608	A-1075	R-21357	Lower Tail Lamp Unit Assembly
8	0608	A-1074	R-21355	Upper Service Assembly—Tail and Stop Lamp Assembly (Left)

## ELECTRICAL TROUBLES AND REMEDIES

### SYMPTOMS

#### Lights Burn Dim

- Loose or dirty terminals.....
- Leak in wires.....
- Poor switch contact.....
- Poor ground connection.....
- Poor plug connection.....
- Battery in truck not fully charged.....

- Clean and tighten
- Check entire circuit for broken insulation
- Install new switch
- Clean and tighten
- Re-connect to get good contact
- Recharge or replace

#### Do Not Light

- Bulb burned out.....
- Broken wire.....
- Connector dirty or loose.....
- Trailer light switch not fully on.....
- Trailer light switch in wrong position.....
- Ground connection poor.....
- Coupling socket connection poor.....
- Wires loose on switch or socket.....

- Replace service unit
- Splice and tape
- Clean and repair
- Switch on
- Turn switch
- Clean and tighten
- Re-connect
- Tighten

#### Wrong Lights On

- Connectors at light in wrong sockets.....
- Trailer light switch turned to wrong position....

- Change around
- Turn switch

## ELECTRICAL SYSTEM SPECIFICATIONS

#### Lamps:

- Light switch make..... Douglas
- Coupling and socket..... Wagner
- Tail and stop lamps..... Willys—Corcoran-Brown; Bantam—Arrow Safety
- Tail and stop lamp bulbs 6-8V 3-21CP, DC... Mazda No. 1154—6-8V 3 CP. SC... Mazda No. 63
- Blackout bulbs—6-8V 3CP. SC..... Mazda No. 63



## AXLE

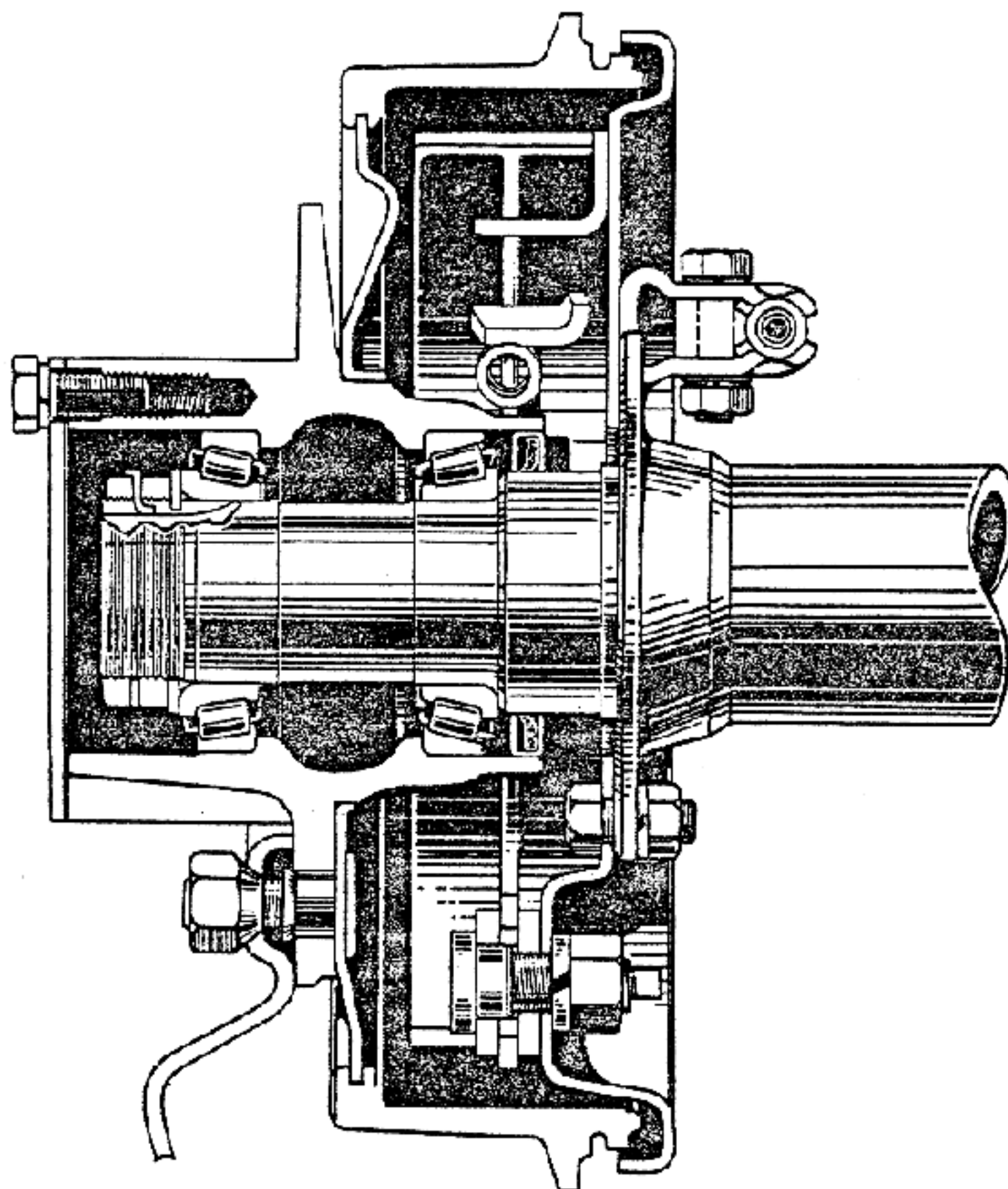

FIG. 7—SECTIONAL VIEW OF AXLE

The axle, Fig. 7, is of the tubular type. Wheels are supported on two taper roller bearings on the axle housing. The bearing races are pressed into the wheel hub and the adjustment of the bearings made by adjusting nuts on each end of the axle.

A removable steel cover or cap is used on the wheel hub to permit inspection and access to the wheel bearings.

### Removing Axle from Vehicle

To remove the axle, first raise the vehicle and support the frame under the body so that the wheels will clear the floor. Next remove six screws and the wheel hub cap from each wheel; bend back lugs on the wheel bearing outer nut lockwasher, remove nut, washer and wheel bearing adjusting nut after which remove wheel and hub assembly.

Remove six bolts from the brake backing plates. Next remove the axle spring clip nuts and clips after which the axle can be removed from the vehicle.

Reassembly is the reverse procedure. Due attention should be given to the wheel bearings so that they are properly adjusted. Tighten the inner adjusting nut until the wheel binds, at the same time rotate the wheel and make sure that all surfaces are seating properly. Back off the nut  $\frac{1}{8}$  turn or more, if necessary, until the wheel turns freely, after which replace the outer nut lock washer and lock nut and be sure to bend over the lock washer lug. Make sure wheel turns freely after tightening lock nut. See Lubrication Section for details concerning proper lubricant.



## AXLE TROUBLES AND REMEDIES

SYMPTOMS	PROBABLE REMEDY
<b>Swaying</b>	
Bent axle.....	Check and straighten
Broken spring main leaf.....	Replace
Axle shifted.....	Spring center bolt broken
Loose spring shackles or clips.....	Adjust or replace
Tire pressure uneven.....	Inflate to 30 lbs.
Loose wheel bearings.....	Adjust
Broken wheel bearing.....	Replace
Springs settled or broken.....	Repair or replace
Trailer load on one side.....	Reload to distribute weight
One brake dragging.....	Adjust

## AXLE SPECIFICATIONS

<b>Axle</b>	
Type.....	Tubular
Tread.....	49"
<b>Bearings</b>	
Make—Wheel Hub.....	Timken
Cone and Roller.....	Inner 18590    Outer 18590
Cup.....	Inner 18520    Outer 18520

# BRAKES

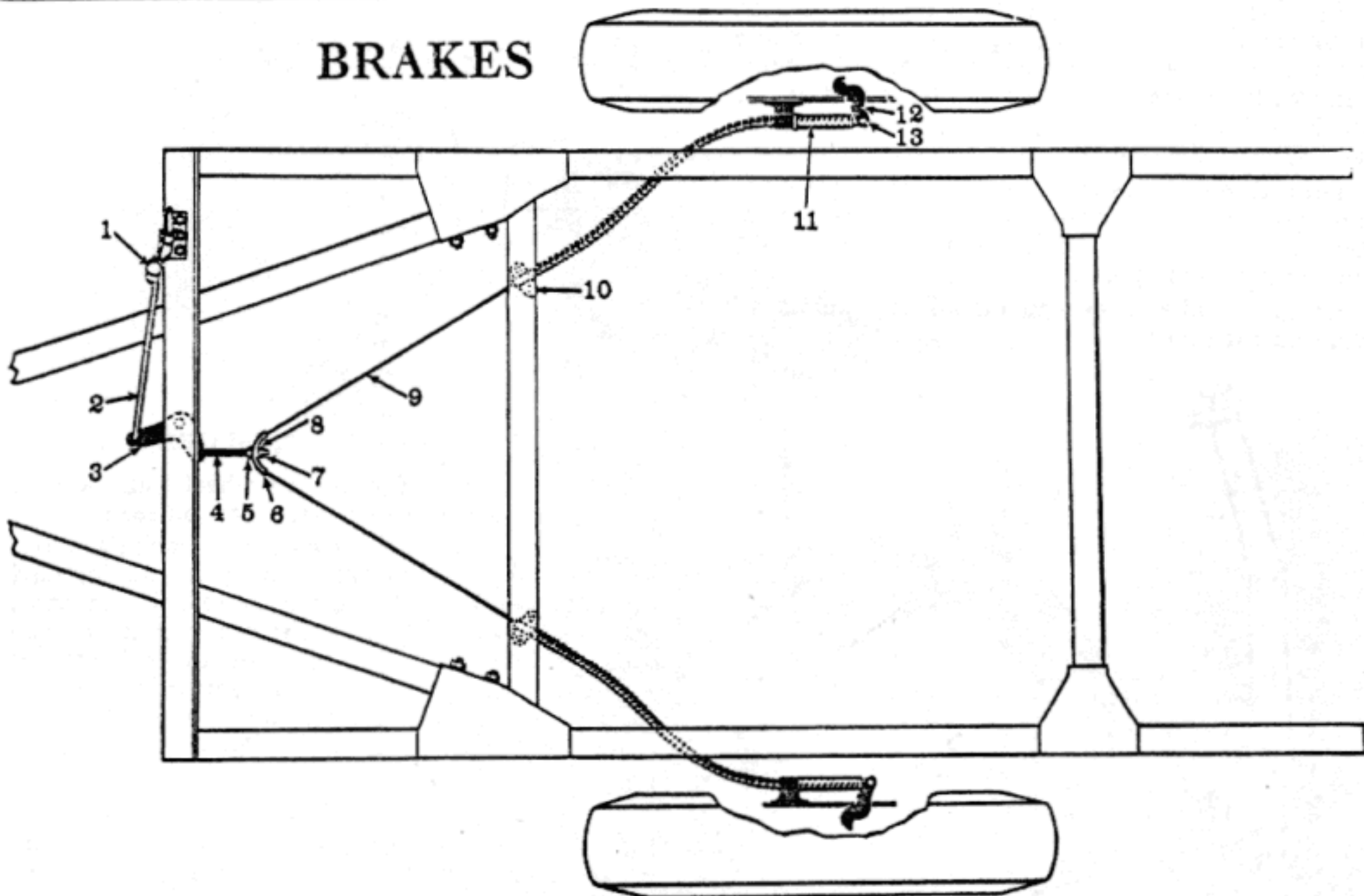

FIG. 8—BRAKE SYSTEM

Item No.	Gov't Group No.	Bantam Part No.	Willys Part No.	Name
1	1201	14302	A-6378	Hand Brake Lever Assembly Complete
2	1201	14305	A-6400	Hand Brake Lever Rod
3	1201	14306	A-6000	Hand Brake Bell Crank
4	1201	14328	A-6518	Hand Brake Cable Hook Bolt
5	1201	31x2-R	50802	Hand Brake Cable Hook Bolt Nut
6	1201	14327	A-6768	Hand Brake Cable Equalizer
7	1201	35x27	53049	Hand Brake Cable Hook Bolt Pal Nut (Lock Nut)
8	1201	31x2-R	50802	Hand Brake Cable Hook Bolt Nut

Item No.	Gov't Group No.	Bantam Part No.	Willys Part No.	Name
9	1201	14325	A-6406	Hand Brake Cable and Conduit Assem.
10	1201	14156	A-6766	Hand Brake Cable Conduit to Frame Clip
11				Hand Brake Return Spring (Part of Cable)
12	1203	14372	637906	Hand Brake Cam Lever
13	1201	14436	A-6526	Hand Brake Cable Clevis Pin (End to Cam Lever)

The Brake System is a hand operated parking brake, Fig. 8. The brakes are the Bendix, internal expanding, double anchor, two shoe type, cable controlled. The hand lever is on the front side of the body at the right; pull to the right to apply the brakes. A button type release is located in the top of the lever.

When the hand lever goes almost to the limit of the ratchet quadrant, adjust the brakes as follows:

Jack up the wheels to clear the floor. With a wrench loosen the lock nut Fig. 9, No. 1, on the forward brake shoe. Hold lock nut and with another wrench turn the eccentric toward the front of the vehicle until the brake shoe strikes the drum, then turning wheel with one hand release the eccentric until the wheel turns freely; hold the eccentric and tighten the lock nut. Repeat this operation on the reverse shoe only turn the eccentric toward the back of the vehicle. Do this on both wheels.

### Brake Shoe Adjustment—Major

To make major brake adjustment involving the setting of the anchor pins, Fig. 9, No. 2; after the above minor adjustment, loosen the anchor pin lock nuts on the rear of the backing plate and turn the eccentric anchor pins toward each other and down until the shoes are set to the proper clearance .005 inch clearance at the heel (lower end) and .008 inch at the toe (upper end) of the brake shoe lining as

determined by feeler gauges. A slot is provided in the brake drum for checking these clearances when the wheel is off. Do this on both wheels.

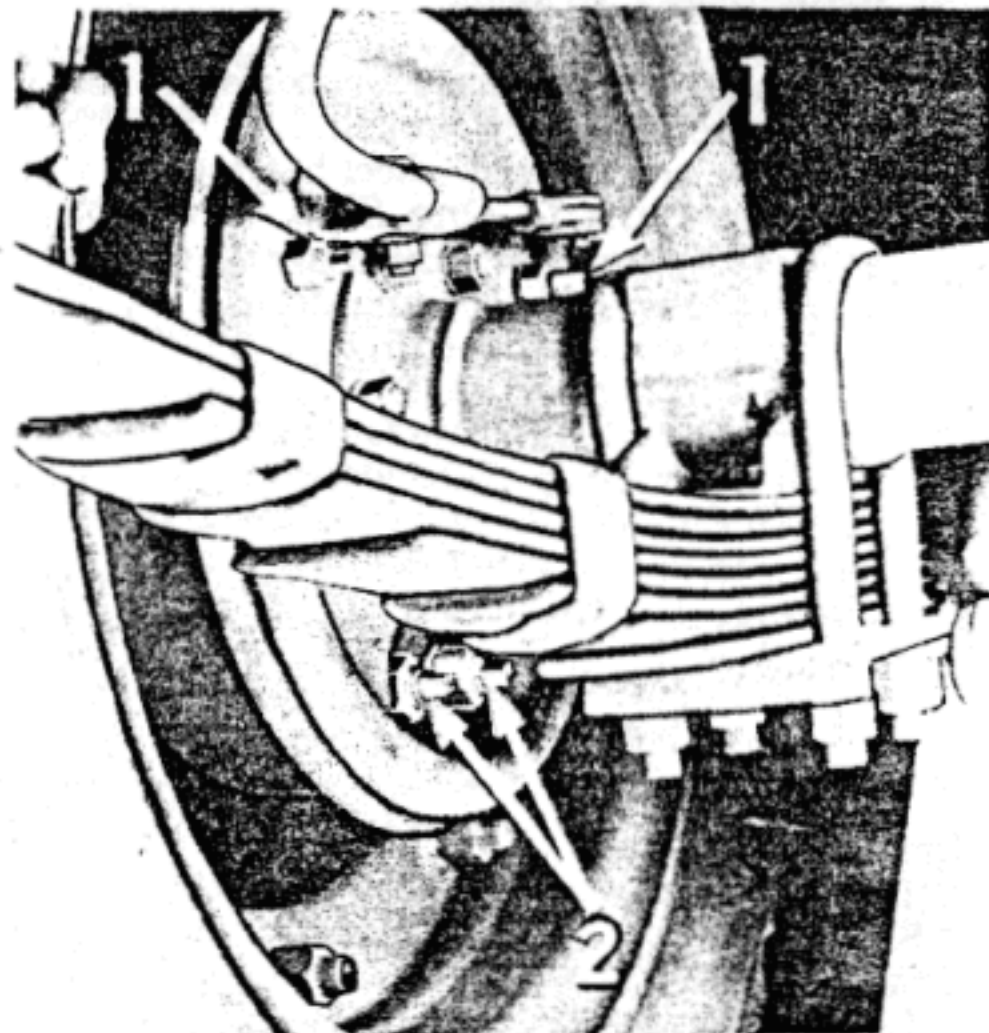

FIG. 9—BRAKE ADJUSTMENTS

**Relining Brakes**

Relining of brakes will not be required except in unusual instances. When necessary to reline the brakes, raise both wheels free from the floor. Remove the wheels and then the hubs and drums which will then give access to the brake shoes. See "Wheel" Section, Pg. 15, for instructions.

Turn all eccentrics to the lower side of the cam, and then remove the brake shoe contracting spring. Remove anchor pin nut, lockwashers and anchor pins from backing plate.

Remove brake shoes and install new linings or replacement shoes.

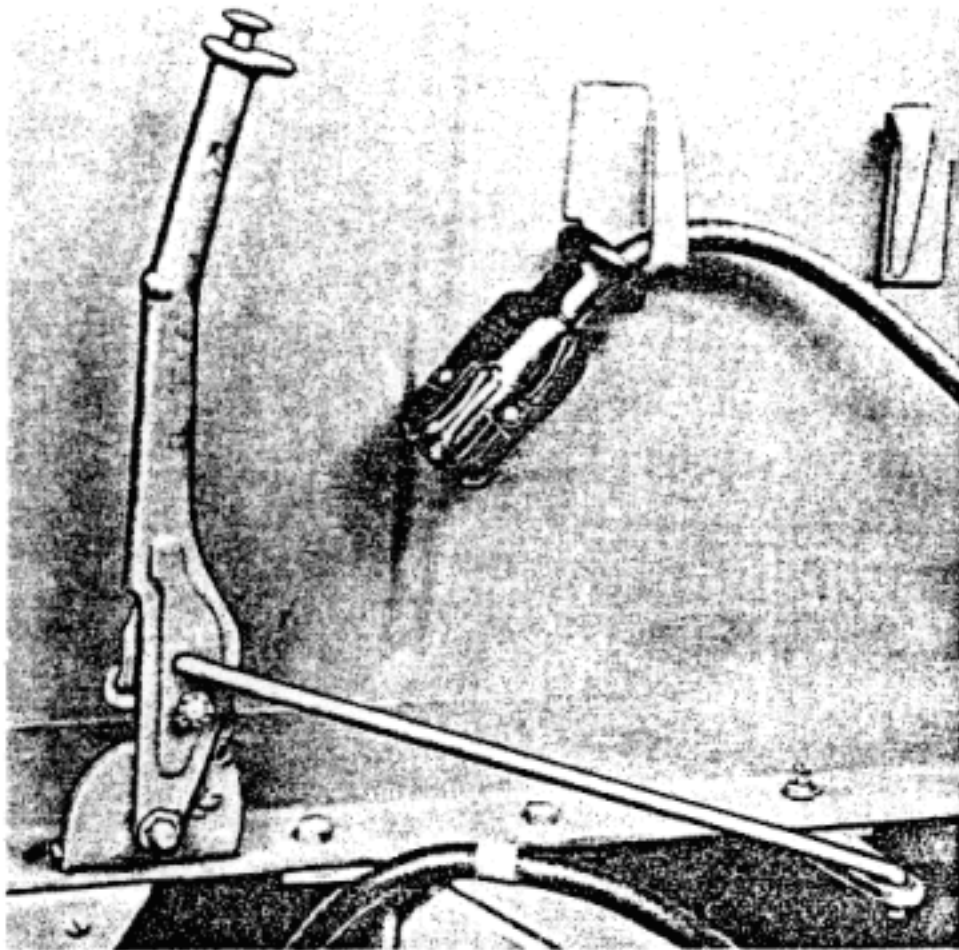

FIG. 10—HAND BRAKE LEVER

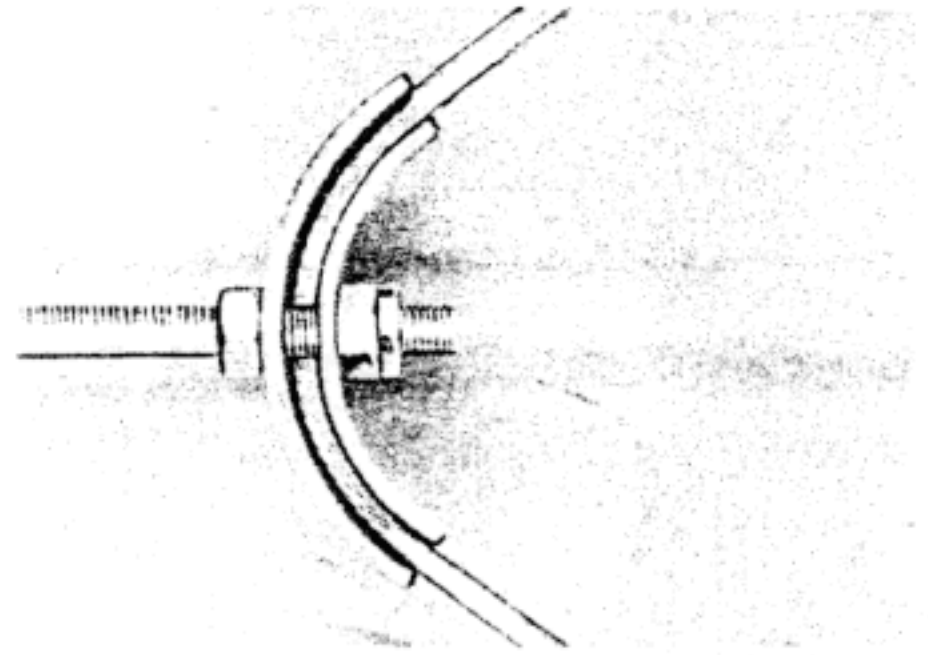

FIG. 11—BRAKE EQUALIZER

Inspect the oil seals in the wheel hubs and if grease has been leaking, install new oil seals.

Install brake shoes on the brake backing plate, the shoe with the longest lining is the forward shoe. Install anchor pin, pin plate and pin cam; then install anchor pins so the punch mark on the ends are facing each other. Install lock washer and nut, install brake shoe returning spring. Install the hubs and drums, then make a "Major" adjustment of the brakes. See Pg. 13.

**Hand Brake**

The brake system should be adjusted only after the wheel brakes are adjusted. Pull up the hand brake lever, Fig. 10, two notches and adjust the brake cable hook bolt No. 4 in Fig. 8 by loosening the lock nuts on either side of the cable equalizer. See Fig. 11. Take up the adjustment until a slight drag is felt at the wheels, then lock in place. The wheels must be free from drag when the hand brake is released.

**BRAKE TROUBLES AND REMEDIES**

**SYMPTOMS**

**PROBABLE REMEDY**

**Brakes Drag**

- Brake shoes improperly adjusted.....
- Lever does not fully release.....

- Readjust
- Lubricate cables in conduits.

**One Brake Drags**

- Cable stuck.....
- Brake shoe adjustment incorrect.....
- Retracting spring broken.....
- Loose or damaged wheel bearings.....

- Free and lubricate
- Adjust
- Replace
- Adjust or replace

**Trailer Pulls to One Side**

- Brake anchor pin adjustment incorrect.....
- Dirt between lining and drum.....
- Drum scored or rough.....
- Loose wheel bearings.....
- Axle spring clips loose.....
- Brake backing plate loose.....
- Tires under-inflated.....
- Tires worn unequally.....

- Adjust
- Clean with wire brush
- Turn drum and replace lining
- Adjust
- Tighten
- Tighten
- Inflate to 30 lbs. pressure
- Replace

**Brakes Do Not Hold**

- Oil on lining.....
- Improperly adjusted.....
- Brake lever or cable stuck.....

- Replace lining
- Major adjustment
- Free and lubricate

**BRAKE SPECIFICATIONS**

**Brakes**

- Type.....2 Wheel Mechanical
- Size.....9" x 1 3/4"
- Brake Shoes.....Bendix
- Lining area (total).....58.79 Sq. in.
- Length Lining—Forward shoe.....10 7/32"
- Length Lining—Reverse shoe.....6 37/64"

- Width.....1 3/4"
- Thickness.....3/16"
- Brake Return Springs:**
- Brake Shoe Return Spring**
- Free Length.....5 13/16"
- Load when extended to 6 3/16".....40 lbs.



# WHEELS—WHEEL BEARINGS

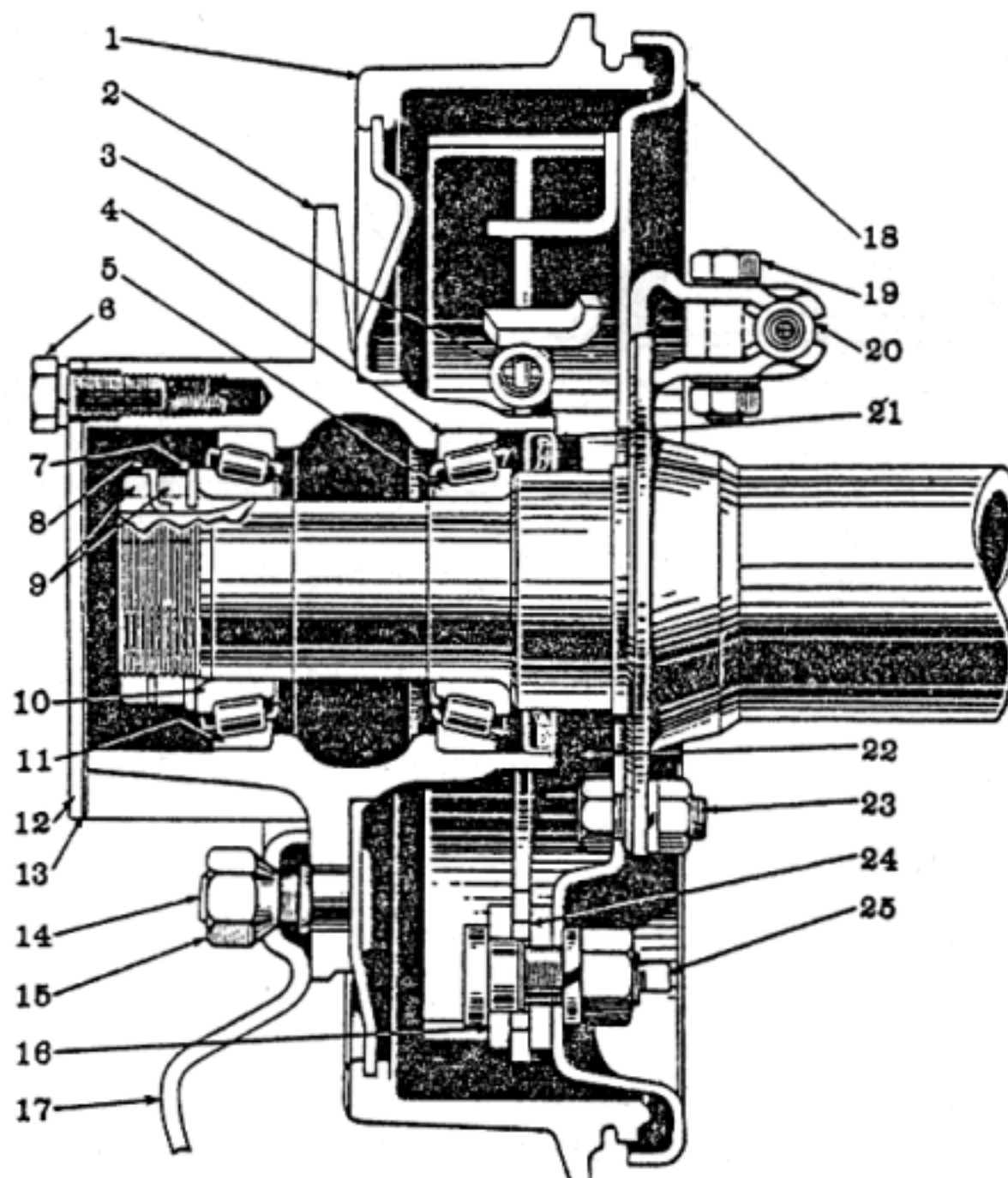

FIG. 12—WHEEL BEARINGS

Item No.	Gov't Group No.	Bantam Part No.	Willys Part No.	Name
1	1302	R-20731	A-472	Brake Drum
2	1302	R-10111	A-1691	Wheel Hub (with Bearing Cups)
3	1203	14371	637905	Brake Shoe Return Spring
4	1302	R-21160	52943	Roller Bearing Cup
5	1302	R-21159	52942	Coned Roller Bearing
6	1302	1X10-R	6299	Hub Cap Screw
7	1302	R-21161	A-865	Outer Wheel Bearing Washer
8	1302	R-21163	A-867	Outer Wheel Bearing Nut Lockwasher
9	1302	R-21162	A-866	Wheel Bearing Nut
10	1302	R-21159	52942	Cone and Roller Bearing
11	1302	R-21160	52943	Roller Bearing Cup
12	1302	14255	A-6038	Hub Cap
13	1302	R-21031	A-904	Wheel Flange Gasket
14	1302	R-20051	A-473	Wheel Hub Bolt L.H. thd. (Wilys A-474; Bantam R-20050, R.H. thd.)

Item No.	Gov't Group No.	Bantam Part No.	Wilys Part No.	Name
15	1302	R-11028	A-475	Wheel Hub Bolt Nut L. H. thd. (Wilys A-476; Bantam R-11027, R.H. thd.)
16	1203	14369	637901	Brake Shoe Anchor Pin Plate
17	1301	14231	A-5467	Divided Combat Wheel Assembly
18	1208	14358	A-6458	Brake Backing Plate Assembly L.H. (Wilys A-6459; Bantam 14357, R.H.)
19	1208	1X46-R	6609	Conduit Bracket Backing Plate Screw
20	1201	14325	A-6406	Cable and Conduit Assembly
21	1302	R-21164	A-864	Hub Oil Seal Assembly
22	1202	14359	116549	Brake Shoe Lining Assembly—Forward (Wilys 116550; Bantam 14362, Reverse)
23	1200	1X26-R	A-903	Brake Backing Plate Screw
24	1203	14388	637900	Brake Shoe Anchor Pin Cam
25	1203	14367	637899	Brake Shoe Anchor Pin

The wheels are carried on two opposed tapered roller bearings. Bearings are adjustable for wear and their satisfactory operation and long life depend upon periodic attention and correct lubrication. See Fig. 12.

Wheel bearings cannot be checked for adjustment properly unless brakes are free from dragging on brake drums and are in fully released position.

### Wheel Bearings

1. Raise vehicle with jack so that tires clear the floor.
2. With hands test sidwise shake of the wheel. If bearings are adjusted too loose, shake of wheel will be perceptible. If bearing adjustment is too tight, the bearings will bind and the rollers may break or become overheated.

If this test indicates adjustment is necessary, proceed as follows:

### Adjustment

1. With wheels still on jack remove hub cap.
2. Bend lip of nut lockwasher so that adjustment locknut and lock can be removed.
3. Tighten adjusting nut until wheel binds, at the same time rotating wheel to make sure all bearing surfaces are in proper contact.
4. Then back off nut about 1/8 turn or more if necessary making sure wheel rotates freely.
5. Replace locknut and lockwasher. Do not fail to bend over lip on nut lockwasher.
6. When hub is completely assembled, test wheel shake before removing jack.

When reinstalling hubs and drums, the hubs with the right hand threaded studs are placed on the right hand side of vehicle. The left hand threaded studs are on the left hand side, viewing vehicle from the rear.



## Brake Drum

The brake drums are attached to the wheel hubs by five serrated bolts. These bolts are also used for mounting the wheels to the hubs.

To remove a brake drum, drive out the serrated bolts and remove the drum from hub.

When placing drum on hub, make sure that the contacting surfaces are clean and flat. Line up holes in drum with those in hub and force drum over shoulder on hub. Insert five new serrated bolts through drum and hub and drive the bolts into place solidly. Place a round piece of stock in vise approximately the diameter of the head of the bolt and place hub and drum assembly over it so that it rests against head of the bolt then swedge bolt into countersunk section of hub with punch.

The runout of the face of the drum should be within .003". If runout is found to be greater than .003" it will be necessary to reset bolts to correct the condition.

Left hand hub bolts are identified with an "L" stamped on head of the bolt.

The left hand threaded nuts can be identified by a groove around the hexagon faces.

Hubs containing the left hand threaded hub bolts are installed on the left hand side of vehicle.

## Tires

One of the most important factors of safe vehicle operation and probably the most neglected is correct tire maintenance. Tires must sustain the weight of the loaded vehicle, withstand more than ordinary rough service, provide maximum safety over all types of territory, and furnish the medium on which the vehicle can be maneuvered with ease.

Tire pressures should be consistently maintained for safe operation. An under inflated tire is dangerous and too much flexing causes breakage of the casing fabric resulting in a failure. Over-inflation in time may cause a blowout. Inflate tires to 30 pounds pressure.

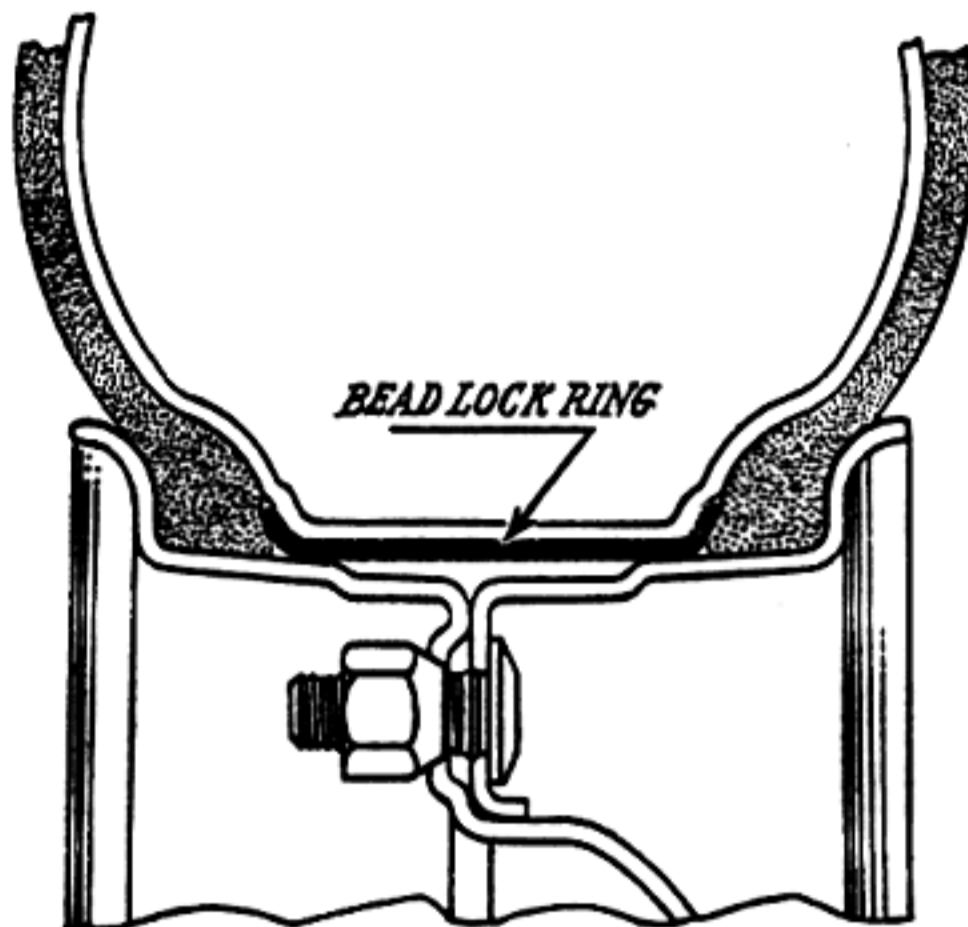

FIG. 13—COMBAT WHEEL

When removing a tire, first remove the wheel and be sure to deflate the tire before removing the rim nuts. After removing the rim nuts, remove the outer rim then remove the tire after which remove the bead locking ring and tube from the tire. When mounting the tire the procedure is reversed. See Fig. 13. Do not put too much air in the tube when mounting. Combat wheel rim bolt and hub bolt torque reading 60-70 ft. lbs.

When tightening the wheel stud nuts, alternately tighten opposite nuts to prevent wheel runout. After nuts have been tightened with the wheel jacked up, lower jack until wheel rests on the floor and retighten the nuts.

## WHEEL SPECIFICATIONS

### Wheels:

Make.....Kelsey-Hayes  
Rim.....16x4.50 Combat Wheels

Tires.....Straight Side—6 Ply—16 x 6.00

Type Tread.....Non-directional

Make.....Goodyear "All Service"

Tire Pressure.....30 lbs.

### Bearings:

	Inner	Outer
Make.....	Timken	Timken
Cone and roller.....	18590	18590
Cup.....	18520	18520

## FRAME

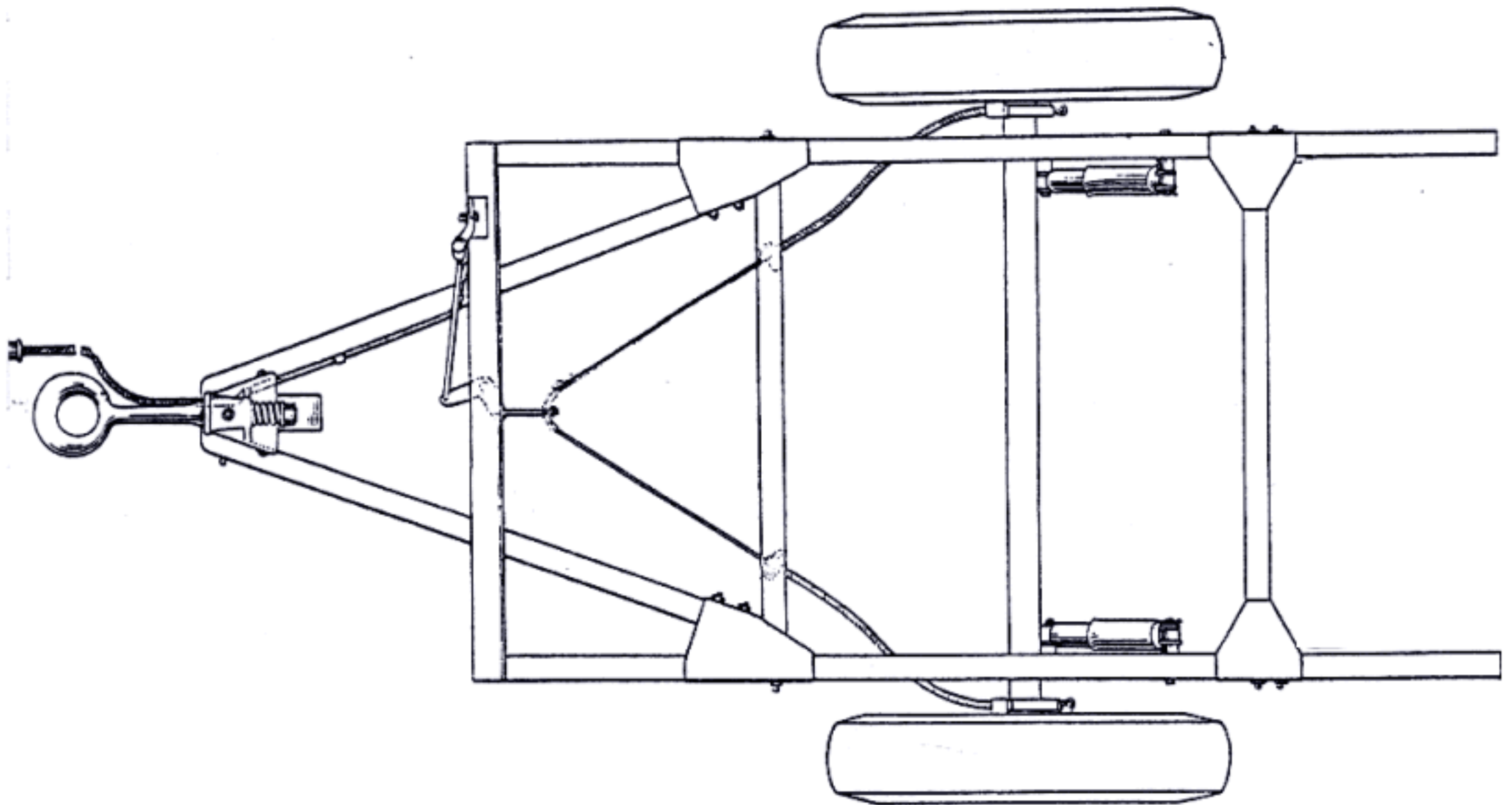

FIG. 14—FRAME

The frame assembly Fig. 14 is constructed of heavy channel steel draw bars with angle steel side members welded into one unit with the body. This is reinforced so that it has a high factor of safety. The draw-bar and side rails are bolted together to simplify replacement. Due to this rugged design, the frame requires very little attention other than to see that the bolts are kept tight. Vehicles which have been in an accident of any nature which may result in swayed or sprung parts should be carefully checked for proper alignment to avoid tire wear.

### Checking Alignment

When checking the frame or draw-bar for alignment, the most efficient method is the "X" checking on given points on each side rail. The most convenient way to check alignment is to turn the trailer bottom side up. Checking should be done

from the front end of each frame side rail, also from the rear end. The draw-bar should be checked to see that it is in alignment with the frame side rails.

### Straightening Frame

Where the bending or twisting of the side rails or draw-bar is not excessive, they may be straightened. Do not apply excessive heat, for it may weaken the frame. It is recommended that badly damaged draw-bar parts be replaced.

### Draw-Bar Support Leg

The draw-bar support leg Fig. 15 is controlled by a locking plunger, which is operated by pulling out on the handle on the left side. Three different positions are available. When the draw-bar leg is down to support the weight of the trailer, be sure that it is locked in the forward position. A half raised position is available.

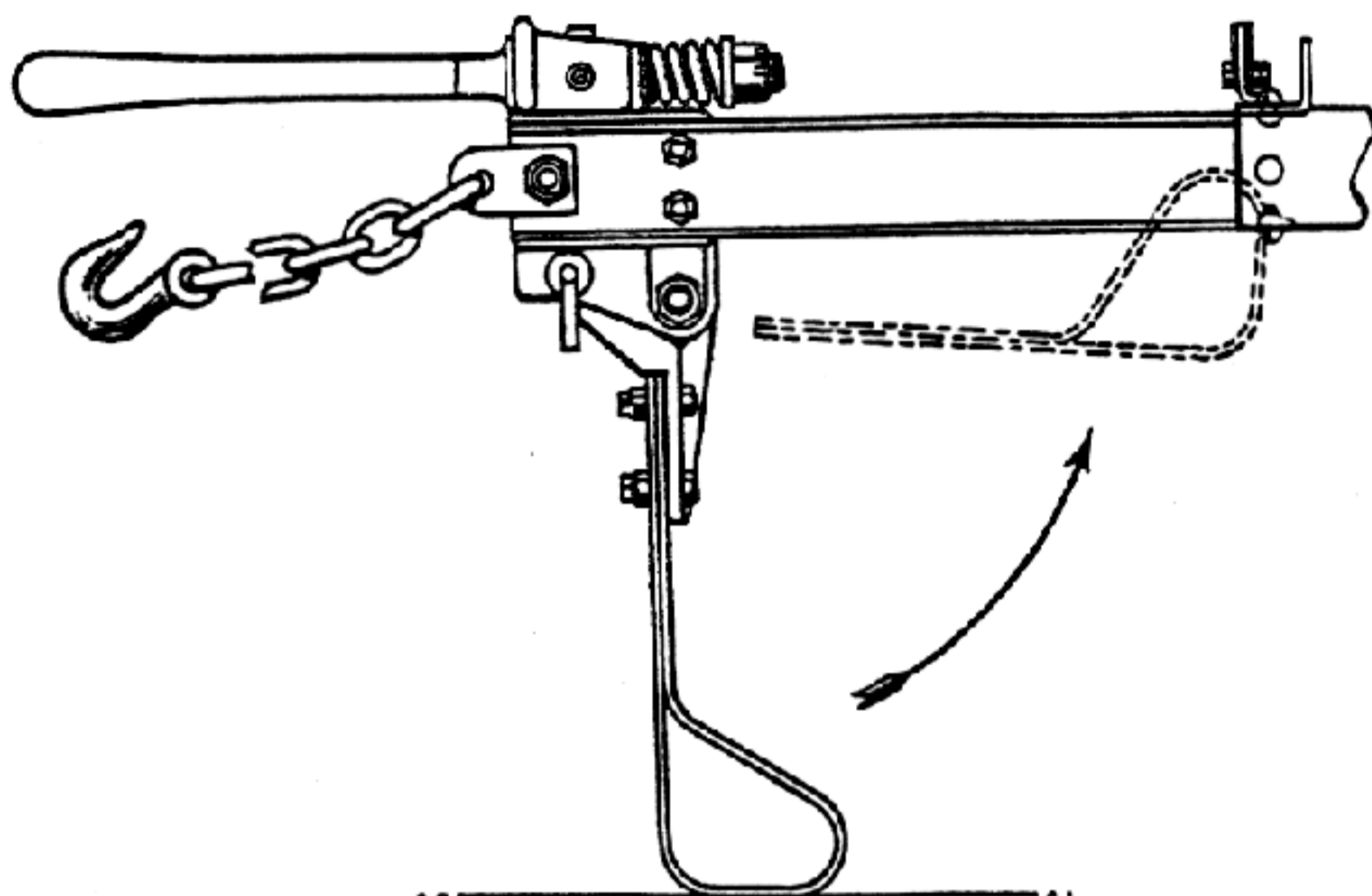

FIG. 15—LUNETTE EYE AND SUPPORT

## FRAME SPECIFICATIONS

### Frame

Frame Width.....	37 $\frac{7}{8}$ "
Number Cross Members.....	3

### Side Members

Depth.....	3 $\frac{3}{16}$ "
Thickness.....	$\frac{3}{32}$ "
Flange Width.....	1 $\frac{3}{4}$ "
Length.....	74"

Draw Bar Type.....	"V"
Channel.....	"U"
Depth.....	3"
Thickness.....	1345"
Flange Width.....	1 $\frac{3}{4}$ "
Length.....	42 $\frac{1}{2}$ "



# SPRINGS

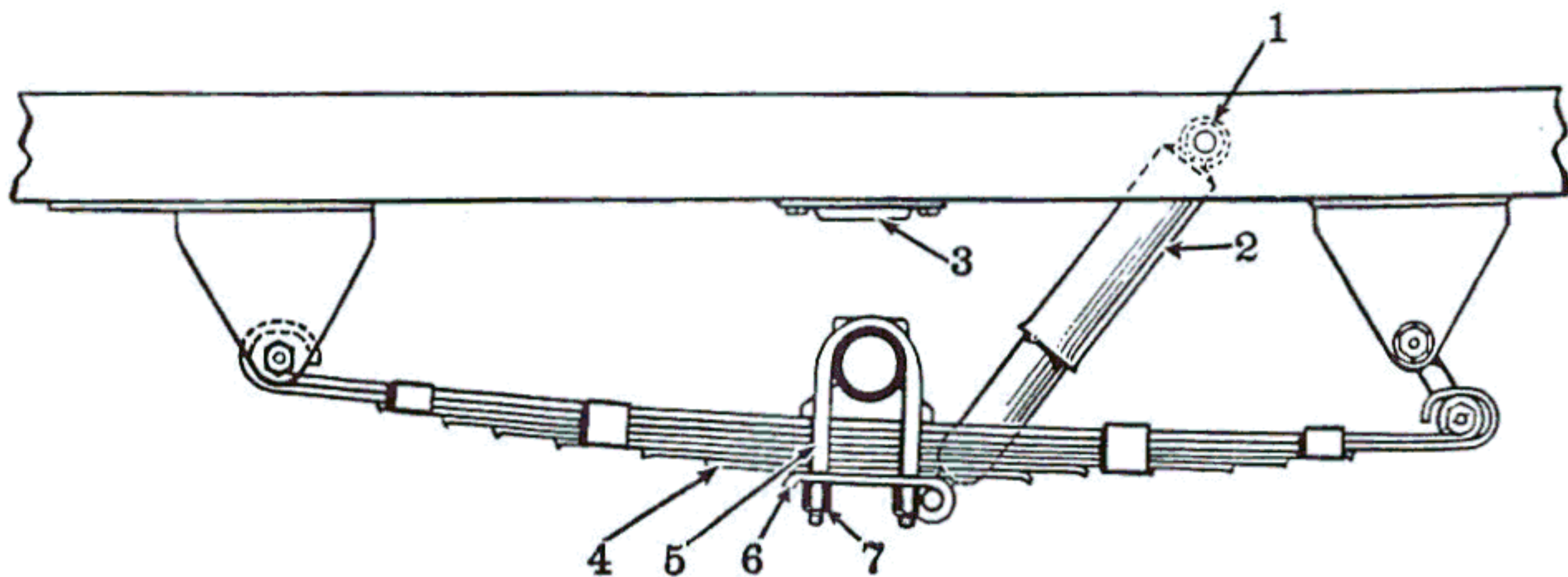

FIG. 16—SPRING AND SHOCK ABSORBER

Item No.	Gov't Group No.	Willys Part No.	Bantam Part No.	Name
1	1603	637936	R-10246	Shock Absorber Mounting Pin Bushing
2	1603	A-169	14297	Shock Absorber Assembly
3	1506	A-6377	14316	Axle Bumper
4	1601	A-612	14268	Spring

Item No.	Gov't Group No.	Willys Part No.	Bantam Part No.	Name
5	1000	A-6511	14257	Spring Clip (Axle to Spring)
6	1000	A-572	14332	Spring Clip Plate and Shaft Assembly—Right
7	1000	A-6508	14421	Spring Clip Nut

The specially designed springs used on this vehicle are constructed of chromium alloy steel to stand the severe service to which they may be subjected.

The springs Fig. 16 are the semi-elliptic type, 36¼" long and 1¾" wide. There are eight leaves in each spring with No. 2 leaf military wrapped over the eye of No. 1 leaf. The cross section of the leaves (except the shortest leaf) is so designed to equalize the stresses of spring action thereby minimizing spring breakage. The ends of the leaves are turned down to eliminate squeaks. Each spring is equipped with four rebound clips.

The spring requires a load of 525 lbs. for a 5/16" camber.

The front end of the spring is bronze bushed and is pivoted by a pivot bolt at frame bracket, flexible "U" shackles are used at the rear.

The spring saddles on axle are welded in place and springs are held in position through "U" bolts, using the spring center bolt inserted in spring saddle to prevent shifting of the axle.

### Spring Shackles and Pivot Bolts

The spring shackles are of the "U" type, Fig. 17, with threaded core bushings using right and left hand threads, depending on which position they are to be used in the chassis.

The bushings are anchored solidly in frame bracket and spring eyes and the oscillation taken between the threads of the "U" shackle and the inner threads of the bushing.

There are three bushings used with right hand threads and one with left hand threads. The

right hand threaded type bushing has a plain hexagon head. The left hand threaded bushing has a groove around the head and is used only in the right rear spring eye. This is to prevent the bushing from turning out due to the load and spring action.

The left hand threaded "U" shackle can be identified by a forged boss on the lower shank of the shackle.

The "U" shackles are installed so that the bushing hexagon heads are to the outside of the frame. When making installation of a new "U" shackle or shackle bushing the following procedure should be followed:

Install shackle grease seal and retainer over threaded end of shackle up to the shoulder. Insert new shackle through frame bracket and eye of spring. Holding "U" shackle tightly against frame, start upper bushing on shackle, care being taken when it enters the thread in the frame that it is not cross threaded. Screw up about halfway, and then start lower bushing holding shackle tightly against spring eye and thread bushing in approximately half way, then alternating from top bushing to lower bushing turn them in until the head of the bushing is snugly against the frame bracket, and the bushing in spring eye is 1/32" away from spring measured from inside of hexagon head to spring.

Lubricate the bushings with chassis lubricant and then try the flex of the shackle, which should be free. If shackle is tight it will be detrimental to the bushings as well as to the spring and it will be necessary to re-thread the bushing on shackle.



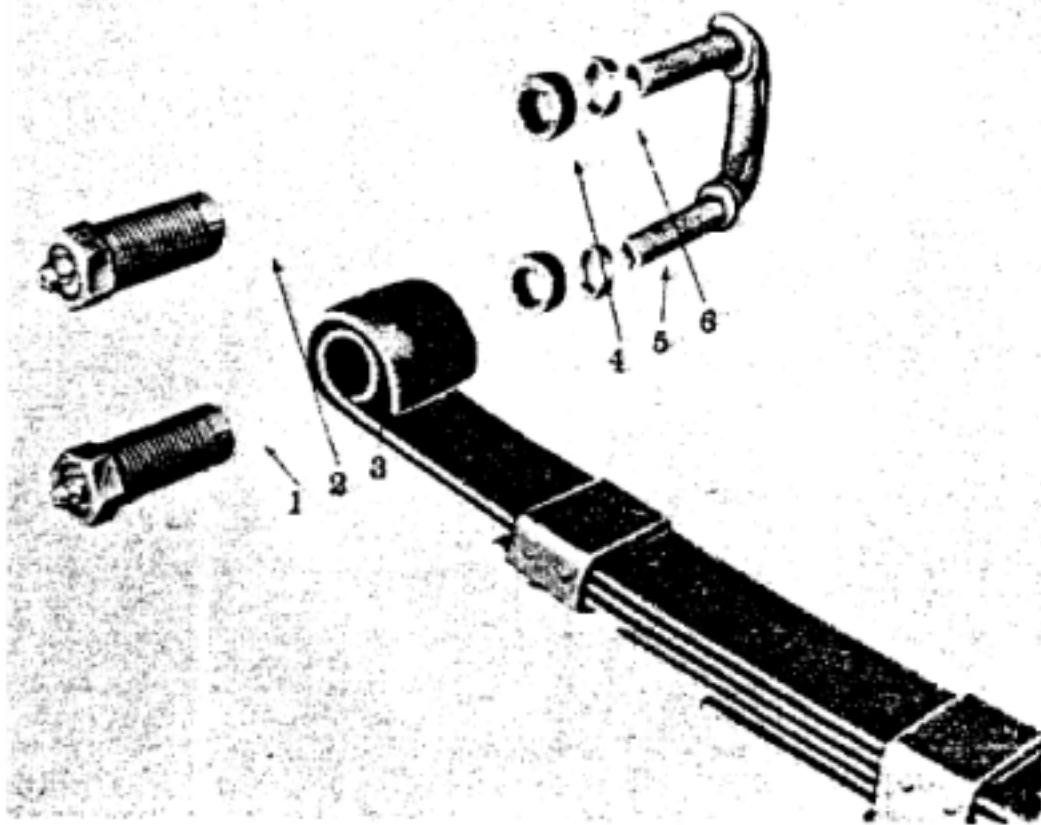

FIG. 17—SPRING SHACKLE—RIGHT SPRING

Item No.	Gov't Group No.	Willys Part No.	Bantam Part No.	Name
1	1602	635532	14315	Spring Shackle Bushing Assembly (L. H. thread)
2	1602	634432	14314	Spring Shackle Bushing Assembly (R.H. thread)
3	1601	A-612	14268	Spring Assembly
4	1602	A-515	14408	Spring Shackle Grease Seal
5	1602	A-513	14313	Spring Shackle U-Bolt (L.H. thread)
6	1602	A-1252	14409	Spring Shackle Grease Seal Retainer

### Remove and Replace Spring

To remove a spring raise the vehicle, then place two stand jacks under frame side rail, adjusted to a distance so that the load is relieved on the spring and yet the wheel still rests on the floor, remove the four axle "U" bolt nuts and lock washers. Remove spring plate. Lower jack at side rail so that the spring is free from axle.

Remove spring front bolt nut and drive out bolt from spring bracket and bushing Fig. 18.

Remove bushing from "U" shackle.

To install spring, replace front bolt first and then the "U" shackle bushing. Raise jack and place center bolt in spring saddle and install "U" bolts and nuts. "U" bolt nut, torque wrench reading, 50-55 ft. lbs.: Spring front bolt nut, 27-30 ft. lb.

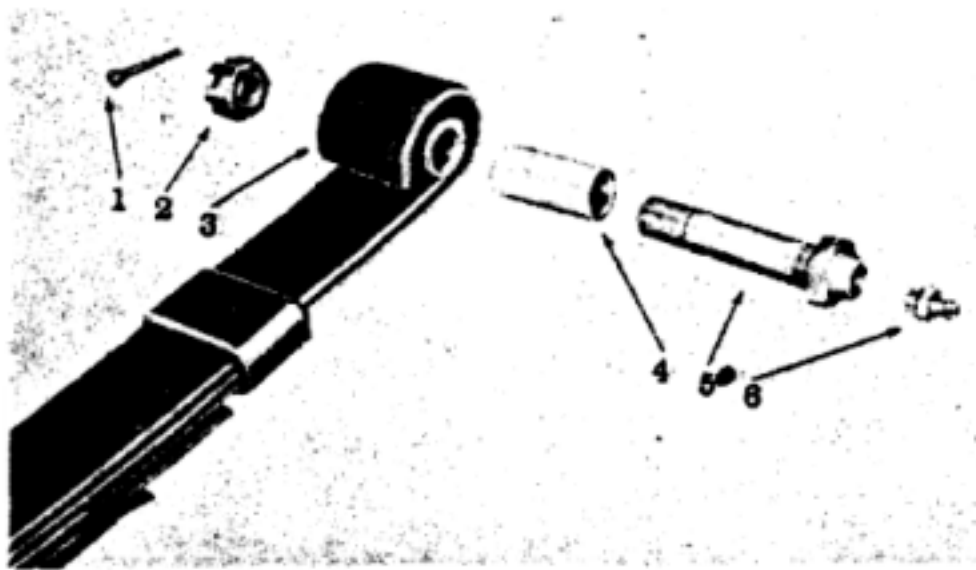
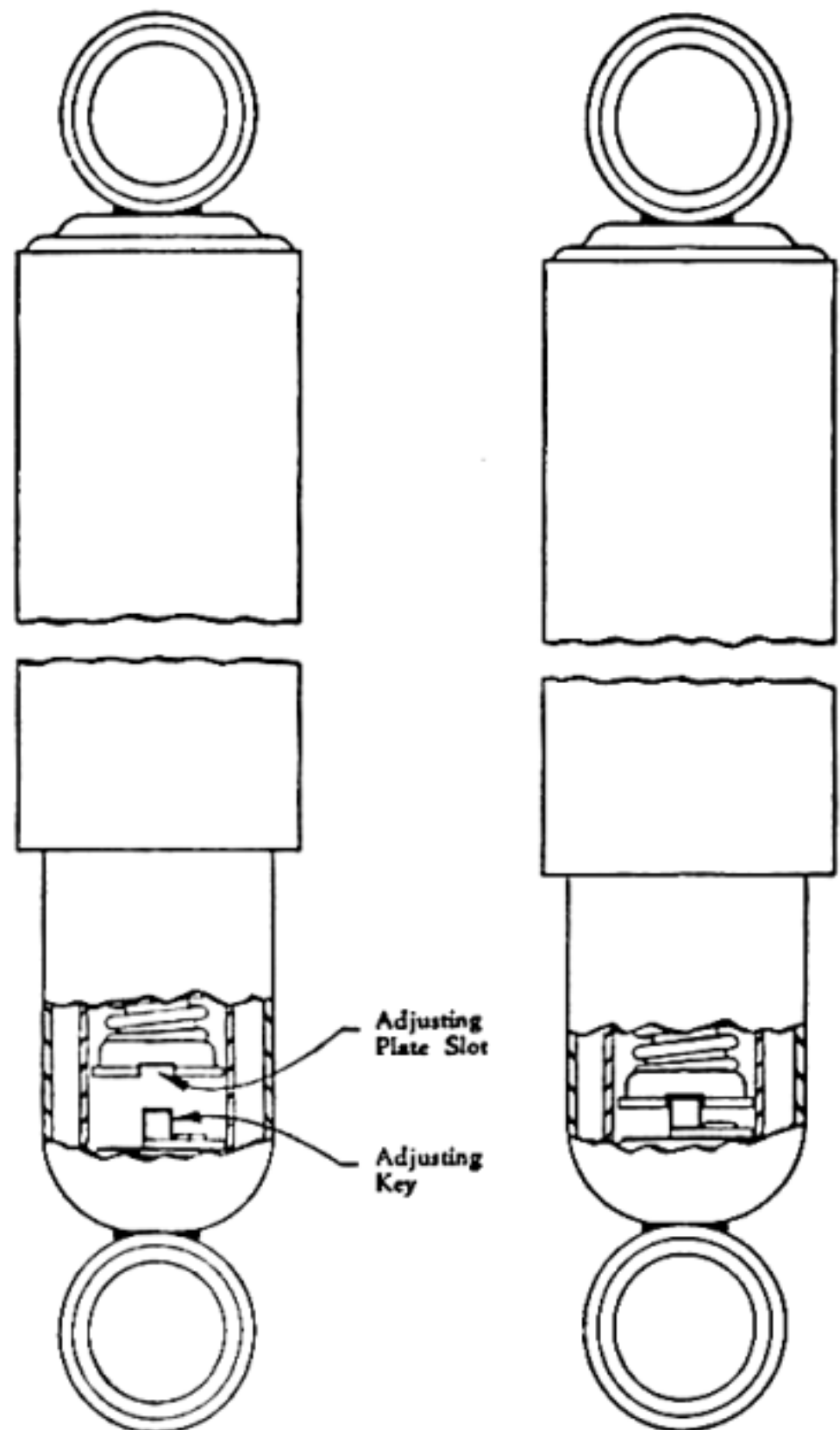

FIG. 18—SPRING BOLT

Item No.	Gov't Group No.	Willys Part No.	Bantam Part No.	Name
1	1506	5021	115x33	Cotter Pin
2	1602	53043	33x51-R	Spring Bolt Nut
3	1601	A-612	14268	Spring Assembly
4	1601	359039	14383	Spring Bolt Bushing
5	1602	384228	14270	Spring Bolt
6	1602	392909	14338	Grease Fittings



Sketch showing shock absorber before engaging adjusting slot and key.

Sketch showing shock absorber completely collapsed with adjusting key engaged in adjusting plate slot.

FIG. 19—SHOCK ABSORBER

### Shock Absorbers

The shock absorbers, Fig. 19 dampen the spring action as the vehicle passes over irregularities in the road.

The shock absorbers are the direct action type, two-way control and adjustable. The range of adjustment is four turns. To adjust the shock absorber, remove the lower end from the spring plate, push the unit together to engage the adjusting key and turn in a clockwise direction until the limit of the adjustment is reached. Holding adjusting key in slot, turn lower end anti-clockwise two turns. This is the average adjustment. Turning the adjustment to the right, or clockwise, gives a firmer control for rough roads, while turning in the opposite direction gives a softer control, allowing faster spring action.

The shock absorber is sealed at the factory with the proper amount of fluid and is non-refillable.

# SPRING AND SHOCK ABSORBER TROUBLES AND REMEDIES

SYMPTOMS	PROBABLE CAUSE AND REMEDY
Breakage—At center Bolt . . . . .	Spring to Axle Clip Nuts Loose—Tighten
Main Leaf Breakage on Ends . . . . .	{ Tight Shackle or Pivot Bolt—Free Up Shock Absorber Control Weak—Adjust No Shock Absorber Control—Replace Springs Lubricated—Discontinue
Excessive Wear on Shackle Bushings . . . . .	
Shock Absorber Noise . . . . .	{ Lack of fluid—Replace Shock Absorber Damaged Cylinder—Replace Shock Absorber Loose Mounting Brackets—Reweld Mounting rubber bushings—Replace
Shock Absorber Control . . . . .	

## SPRING SPECIFICATIONS

### Spring

Make . . . . .	Mather
Type Leaf . . . . .	Parabolic Cross Section
Length Center to Center of Eye . . . . .	36¼"
Width . . . . .	1¾"
Number of Leaves . . . . .	8
Front Eye Center to Center Bolt . . . . .	18½"
Rear Eye Center to Center Bolt . . . . .	18½"
Camber under 525 lbs. . . . .	5/16"
Eye Bushing . . . . .	1¾" long I.D., .5655"
Rebound Clips . . . . .	4

### Shock Absorber

Make . . . . .	Gabriel
Type . . . . .	Hydraulic
Action . . . . .	Double
Length Compressed . . . . .	10 7/16"
Length Extended . . . . .	16 1/8"
Adjustable . . . . .	Yes
Mountings . . . . .	Rubber



## BODY

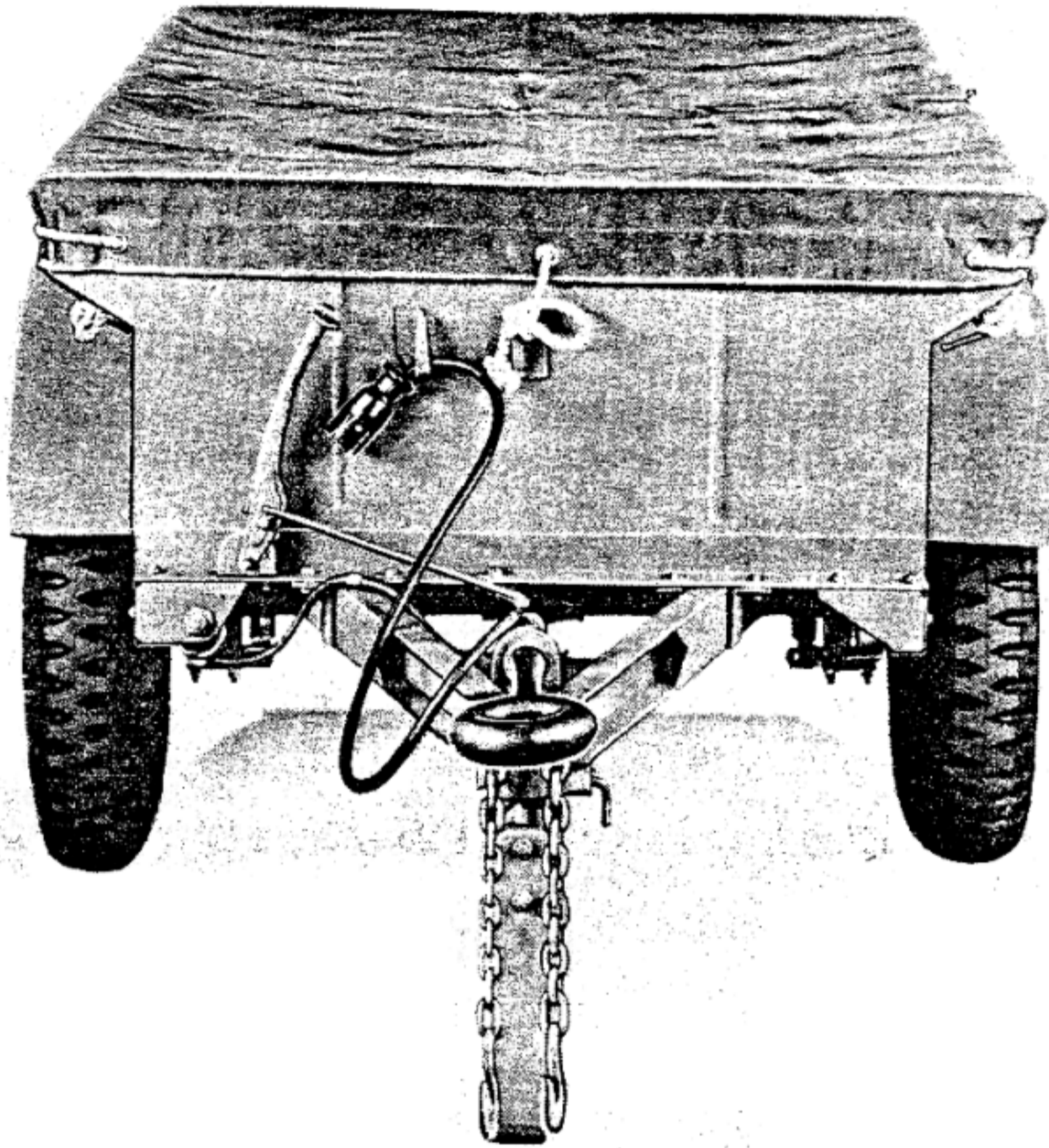

FIG. 20—BODY AND TARPAULIN

The body is of all steel construction and welded into one unit with the frame side rails. The box panels are all of 18 gauge steel strengthened with 16 gauge, 1" O.D. welded tubular frame around the top of the box. All panels have wide welding flanges which strengthen the box and provide large welding and sealing surfaces. They are reinforced with webs for further strength. The box is water tight and will float the vehicle when loaded with a 500 pound load. The water line is 12 inches above the box floor.

A manually operated drain valve is provided in

the right rear corner of the floor which seals against a seat welded to the body.

The fenders are replaceable and bolted to the frame and brackets on the body. The fenders are interchangeable and can be used on either side.

The brake hand lever is mounted on the front side of the body at the right.

A tarpaulin Fig. 20 is provided to cover the box and is held on by taking a half hitch around the body hooks. When not in use it is carried folded in the box.

## TOOLS

The manufacturers of this vehicle recommend the use of special precision tools and close inspection of each part for assurance of proper operation and maximum service.

When necessary special tools facilitate dis-

assembling, checking and reassembling of the unit.

To aid the mechanic in performing satisfactory repairs, we suggest that tools as listed in this section or their equivalent be available when making repairs.

### OPERATING INSTRUCTIONS FOR SERVICE TOOLS

Supplied by Kent-Moore Organization

Detroit, Michigan

Willys  
Part No.

**J-270-1—DRIVER HANDLE.** A heavy duty driving handle with a threaded end, on which can be mounted various adapters for removing and replacing bearing cups, oil seals, etc.

A-6221

**J-1436—WHEEL BEARING CUP AND OIL SEAL AND UTILITY PULLER.** This item is a general utility tool with a wide range of uses such as removing oil seals, bearing cups, etc. Fingers are expanded or retracted by merely turning the handle right or left. A heavy sliding knocker that guides on the tool shaft and strikes against a lug welded to end of shaft, provides powerful leverage in removing parts pressed in place in various assemblies.

A-6226

**J-1743—WHEEL BEARING RACE AND HUB OIL SEAL REPLACER.** Designed to replace the bearing race and oil seal without damage.

A-6230

**J-1744 — WHEEL BEARING ADJUSTING NUT WRENCH AND HANDLE.** This hollow wrench is designed with a pilot guide ring on the inside of the body to prevent the wrench from slipping off the thin adjusting nuts. This construction permits tremendous pressure being applied without danger of the wrench slipping off and injuring the operator.

A-6231

**J-1764—PAIR OF HOOKS FOR REMOVING SPINDLE LOCK WASHERS.** The lock washer which is placed between the bearing adjusting nut and the lock nut has a tongued ear that rides in the spindle keyway. Removal is sometimes difficult because of housing interferences, and these hooks will materially assist in withdrawing the washer from the spindle.

A-6238

**J-1765—BRAKE ECCENTRIC ADJUSTING TOOL.** This tool has two rectangular slots to fit the eccentric adjusting lugs on brake shoe anchor pins. The tool is designed to operate with box type wrenches such as are supplied with mechanics hand tool sets.

A-6239



# PARTS SECTION

FOR

$\frac{1}{4}$  TON—2 WHEEL  
TRAILER

Built For  
U. S. GOVERNMENT

BANTAM  
MODEL T3

Contract Number  
W-2425-qm-672

U. S. A. Reg. Numbers  
0253934 to 0277083

WILLYS  
MODEL MB-T

Contract Number  
W-2425-qm-673

U. S. A. Reg. Numbers  
0212994 to 0244966

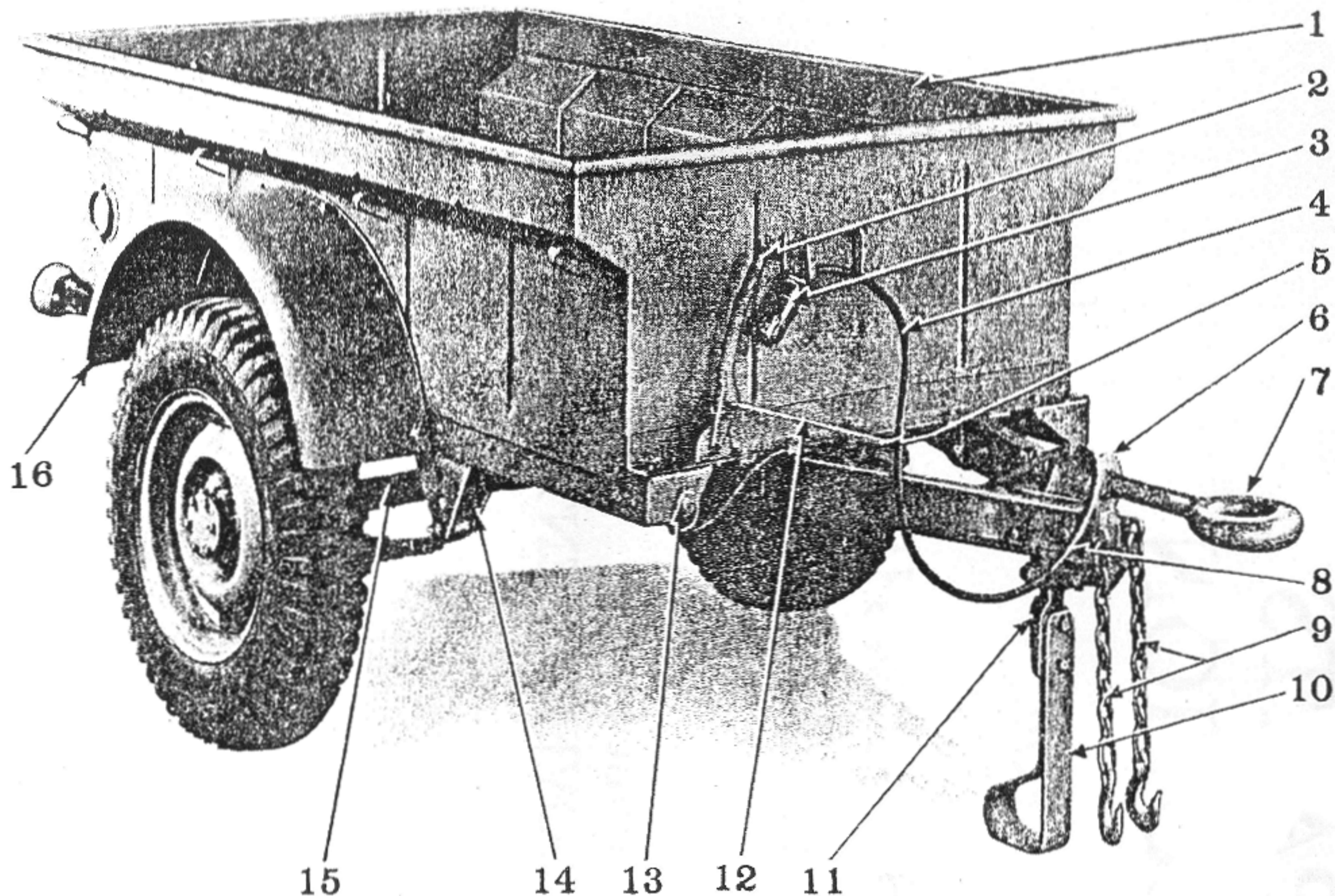

FIG. 21--FRONT VIEW OF TRAILER

Item No.	Gov't Group No.	Bantam Part No.	Willys Part No.	Name	Item No.	Gov't Group No.	Bantam Part No.	Willys Part No.	Name
1	1800	14300	A-3978	Body Assembly Complete	9	1506	14282	A-6392	Safety Chain
2	1201	14302	A-6378	Hand Brake Lever	10	1506	14229	A-6368	Support Leg
3	0606	14448	A-6558	Coupling Socket Cable Plug	11	1506	14228	A-6371	Support Bracket
4	0606	14317	A-6387	Coupling Socket Cable Assembly	12	1201	14305	A-6400	Hand Brake Lever Rod
5	1201	14306	A-6000	Hand Brake Bell Crank	13	0606	14276	A-6021	Blackout Light Switch
6	1506	14269	A-6466	Draw Bar Bracket Assembly	14	1506	14263	A-4005	Spring Pivot Bracket Front
7	1506	14280	A-6370	Lunette Eye	15	1000	14246	A-6823	Axle Assembly
8	0606	14417	A-6557	Coupling Socket Cable	16	1701	14245	A-3994	Fender Assembly



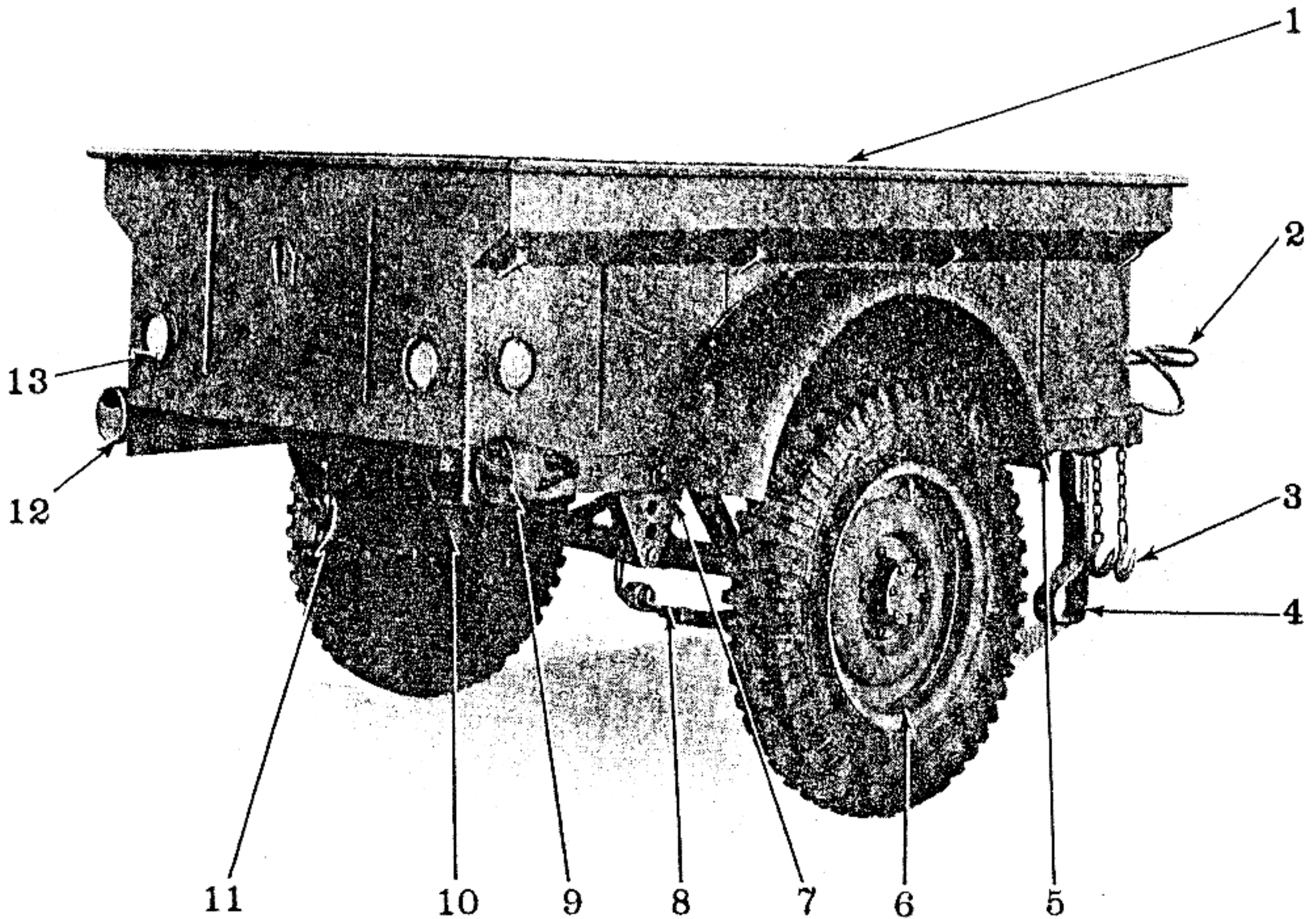

FIG. 22—REAR VIEW OF TRAILER

Item No.	Gov't Group No.	Bantam Part No.	Willys Part No.	Name	Item No.	Gov't Group No.	Bantam Part No.	Willys Part No.	Name
1	1800	14319	A-3977	Body Assembly	8	1601	14268	A-612	Spring Assembly
2	1506	14280	A-6370	Lunette Eye	9	0608	R-11540	A-1065	Tail and Stop Lamp—Right
3	1506	14282	A-6392	Safety Chain	10	1603	14297	A-169	Shock Absorber
4	1506	14229	A-6368	Support Leg	11	1602	14312	A-514	Spring Shackle "U" Bolt
5	1701	14245	A-3994	Fender Assembly	12	0608	R-11544	A-1064	Tail and Stop Lamp—Left
6	1301	14231	A-5467	Wheel Assembly	13	0608	14084	A-1306	Reflex Reflector
7	1506	14394	A-6455	Spring Shackle Bracket—Rear Right					



# ALPHABETICAL INDEX

Description	Gov't Group	Description	Gov't Group
<b>A</b>			
Absorber, Shock—Assembly.....	1603		
Axle Assembly.....	1000		
<b>B</b>			
Body Assembly only—Painted.....	1800		
Body—Complete.....	1800		
Bolt, Cable Hook (Cable Equalizer).....	1201		
Bolt, Divided Rim.....	1301		
Bolt, Hand Brake Lever Fulcrum (3/8"-24 thd. x 1" Special).....	1201		
Bolt, Safety Chain Eye.....	1506		
Bolt, Spring Center.....	1601		
Bolt, Spring—Front.....	1602		
Bolt, Spring Shackle "U"—L.H. thd. (For Right Spring—Rear End).....	1602		
Bolt, Spring Shackle "U"—R.H. thd. (For Left Spring—Rear End).....	1602		
Bolt, Wheel Hub—1/2"-20 L.H. thd.....	1302		
Bolt, Wheel Hub—1/2"-20 R.H. thd.....	1302		
Brace, Spring Pivot—Front.....	1506		
Bracket, Fender Anchor.....	1701		
Bracket, Shock Absorber Mounting—Assembly.....	1800		
Bracket, Spring Pivot—Front.....	1506		
Bracket, Support.....	1506		
Bracket, Tail Lamp—Left.....	1800		
Bracket, Tail Lamp—Right.....	1800		
Bracket and Brace, Left Spring Shackle—Assembly.....	1506		
Bracket and Brace, Right Spring Shackle—Assembly.....	1506		
Bracket and Plunger, Draw Bar—Assembly.....	1506		
Brake Assembly, Left.....	1200		
Brake Assembly, Right.....	1200		
Bumper, Axle.....	1506		
Bushing, Shock Absorber.....	1603		
Bushing, Spring Eye.....	1601		
Bushing, Spring Shackle—Assembly, L.H. thd. (For Right Spring—Rear End).....	1602		
Bushing, Spring Shackle—Assembly, R.H. thd. (For Right Spring—Frame End).....	1602		
Bushing, Spring Shackle—Assembly, R.H. thd. (For Spring and Frame—Rear End—Left).....	1602		
Button, Hand Brake Lever Pawl Rod.....	1201		
<b>C</b>			
Cable, Connector to Blackout Tail Light, Left Side.....	0606		
Cable, Connector to Blackout Tail Light, Right Side.....	0606		
Cable, Coupling Socket—Assembly.....	0606		
Cable and Conduit Assembly.....	1201		
Cam, Brake Shoe Anchor Pin.....	1203		
Cap, Hub.....	1302		
Cap, Tire Valve.....	1301		
Chain, Safety.....	1506		
Channel, "A" Frame—Assembly.....	1506		
Clamp, Cable.....	0606		
Clamp, "A" Frame—Left.....	1506		
Clamp, "A" Frame—Right.....	1506		
Clip, 1/4" (Connector to Blackout Tail Light—Left Side).....	0606		
Clip, 3/16" (Connector to Blackout Tail Light—Left Side) (Trailer Wiring Harness to Body).....	0606		
Clip, 1/16" (Trailer Wiring Harness to Body).....	0606		
Clip, 1/2" (3/32" Hole) (Coupling Socket Cable to "A" Frame Channel).....	0606		
Clip, 5/8" (9/32" Hole) (Coupling Socket Cable to Draw Bar Bracket).....	0606		
Clip, Conduit to Frame.....	1201		
Clip, Spring (Axle to Spring).....	1000		
Clip, Spring—Large.....	1601		
Clip, Spring—Small.....	1601		
Cone and Roller Bearing.....	1302		
Connector, 3-Wire Slip (Trailer Wiring Harness Extension to Blackout Tail Lamp Connector).....	0606		
Crank, Hand Brake Bell.....	1201		
Cup, Roller Bearing.....	1302		
<b>D</b>			
Door, Tail and Stop Lamp—Left.....	0608		
Door, Tail and Stop Lamp—Right.....	0608		
Drum, Brake.....	1302		
<b>E</b>			
Eccentric, Brake Shoe.....	1203		
Equalizer, Cable.....	1201		
Eye, Lunette.....	1506		
Eyelet, 1/2"—No. 4 (Tarpaulin).....	1800		
<b>F</b>			
Fastener, Ring (Tarpaulin Tie Ropes).....	1800		
Fender Assembly.....	1701		
Fitting, Alemite Straight Grease.....	1602		
Fitting, Alemite—Straight—Threaded Drive Type.....	1506		
<b>G</b>			
Gasket, Cover (For Blackout Light Switch).....	0606		
Gasket, Wheel Flange.....	1302		
Grommet 13/32" (Wiring Harness thru cross member).....	0606		
Grommet, 5/8" (Wiring Harness thru Side Member).....	0606		
<b>H</b>			
Handle, Plug.....	0606		
Handle and Sleeve, Plunger—Assembly.....	1506		
Harness, Trailer Wiring (4 Wires in Braided Loom).....	0606		
Hook, (8 reqd. Tarpaulin Rope to Side Panels).....	1800		
(1 reqd. Tarpaulin Rope to Rear Panels).....	1800		
(2 reqd. Tarpaulin Rope to Front Panels).....	1800		
Housing, Assembly.....	0606		
Housing Sub Assembly (Tail and Stop Lamp Body).....	0608		
Hub Assembly.....	1302		
Hub and Drum Assembly, L.H.....	1302		
Hub and Drum Assembly, R.H.....	1302		
<b>L</b>			
Lamp, Tail and Stop—Assembly, Left.....	0608		
Lamp, Tail and Stop—Assembly, Right.....	0608		
Leaf, Spring—No. 1.....	1601		
Leaf, Spring—No. 2.....	1601		
Leaf, Spring—No. 3.....	1601		
Leaf, Spring—No. 4.....	1601		
Leaf, Spring—No. 5.....	1601		
Leaf, Spring—No. 6.....	1601		
Leaf, Spring—No. 7.....	1601		
Leaf, Spring—No. 8.....	1601		
Leg, Support.....	1506		
Lever, Brake—Assembly.....	1203		
Lever, Hand Brake—Assembly, Complete.....	1201		
Lining and Rivets, Brake Shoe—Service Package.....	1202		
Lockwasher, 1/2" Anchor Pin.....	1203		
Lockwasher, No. 8 Keyed.....	0606		
Lockwasher, Outer Wheel Bearing Nut.....	1302		
<b>N</b>			
Nut, 1/16"-20 (For Spring Clip).....	1000		
Nut 1/2"-20 (For Rim Bolt).....	1301		
Nut 1/2"-20 (Left Hand Thread).....	1302		
Nut 1/2"-20 (Right Hand Thread).....	1302		
Nut 7/8"-14.....	0606		
Nut, Anchor Pin.....	1203		
Nut, Brake Disc Screw Nut.....	1200		
Nut, Draw Bar Eye Nut.....	1506		
Nut, Eccentric.....	1203		
Nut, Outer Wheel Bearing.....	1302		



Description	Gov't Group	Description	Gov't Group
<b>P</b>			
Pawl, Hand Brake Lever.....	1201	Service Unit, Tail and Stop Lamp Upper—Assembly, Right.....	0608
Pin, Brake Shoe Anchor.....	1203	Service Unit, Tail and Stop Lamp Lower—Assembly.....	0608
Pin, Clevis (Cable End to Cam Lever).....	1201	Shield, Dust.....	0606
Pin, Hand Brake Bell Crank Pivot.....	1201	Shoe and Lining Assembly, Forward—Brake.....	1202
Pin, Hand Brake Lever Pawl Rod.....	1201	Shoe and Lining Assembly, Reverse—Brake.....	1202
Plate, Backing—Assembly, Left.....	1208	Sleeve, Tire Mounting.....	1301
Plate, Backing—Assembly, Right.....	1208	Sleeve, Insulator.....	0606
Plate, Brake Shoe Anchor Pin.....	1203	Socket, Frame Draw Bar—Left.....	1800
Plate, Cover.....	0606	Socket, Frame Draw Bar—Right.....	1800
Plate, Instruction.....	1301	Spring Assembly (8 leaves).....	1601
Plate, Name.....	2202	Spring, Brake Shoe Return.....	1203
Plate and Shaft Assembly, Spring Clip—Left (On Right Spring).....	1000	Spring, Hand Brake Lever Pawl Rod.....	1201
Plate and Shaft Assembly, Spring Clip—Right (On Left Spring).....	1000	Spring, Lunette Eye.....	1506
Plug, Coupling Socket Cable.....	0606	Spring, Plunger (For Draw Bar Bracket).....	1506
<b>R</b>		Strut, Brake—Left.....	1203
Ratchet, Hand Brake Lever.....	1201	Strut, Brake—Right.....	1203
Reflector, Reflex.....	0608	Support, Body Drain Hole Valve.....	1800
Retainer, Spring Shackle Grease Seal.....	1602	Switch, Blackout Light.....	0606
Ring, Tire Bead Lock (16 x 6.00) (For .55 wide Tire Bead).....	1301	<b>T</b>	
Rivet, Tubular for Brake Lining.....	1202	Tarpaulin Assembly, Complete.....	1800
Rod, Hand Brake Lever.....	1201	Terminal.....	0606
Rod, Hand Brake Lever Pawl.....	1201	<b>V</b>	
Rope, Tarpaulin Anchor Assembly.....	1800	Valve, Body Drain Hole—Assembly.....	1800
<b>S</b>		<b>W</b>	
Screw.....	0606	Washer, Plain.....	0606
Screw, Brake Disc.....	1200	Washer, Special.....	0608
Screw, Frame to Draw Bar Bracket.....	1506	Washer, Eyelet.....	1800
Screw, Safety Chain to Draw Bar Bracket.....	1506	Washer, Lunette Spring, Plain.....	1506
Screw, Support Leg to Support Brace.....	1506	Washer, Lunette Spring (Tongued).....	1506
Screw, Tail and Stop Lamp Door.....	0608	Washer, Outer Wheel Bearing.....	1302
Seal, Hub Oil—Assembly.....	1302	Washer, Special (For Shock Absorber).....	1603
Seal, Spring Shackle Grease.....	1602	Wheel, Divided Combat (16 x 4.50 Rim).....	1301
Seat, Drain Hole Ball.....	1800	Wheel, Inner Half Combat.....	1301
Service Unit, Tail and Stop Lamp Upper—Assembly, Left.....	0608	Wheel and Bolt Assembly, Outer Half Combat.....	1301



## GOVERNMENT GROUPING

Gov't Group No.	Bantam Part No.	Willys Part No.	Description	No. Req.	
<b>0606-Light Switches and Cables</b>					
(See page 9 for Illustration)					
0606	14276	A-6021	Blackout light switch (H. A. Douglas Mfg. Co. No. 6262)	1	
	14401	A-6538	Cover plate (H. A. Douglas Mfg. Co. No. 53238)	1	
	14400	A-6539	Cover gasket (H. A. Douglas Mfg. Co. No. 53189)	1	
	9 x 18-C	53055	Screw No. 10-32 x 3/16" Rd. Hd. (H. A. Douglas Mfg. Co. No. 53338)	3	
	32 x 5	52216	Nut No. 10-32 Hex. (H. A. Douglas Mfg. Co. No. 50904)	3	
	92 x 24-R	52859	Lockwasher No. 10 Shakeproof (H. A. Douglas Mfg. Co. No. 52140)	3	
	14402	A-6540	Nut 7/8"-14 (H. A. Douglas Mfg. Co. No. 53296)	1	
	92 x 36	53054	Lockwasher 7/8" Shakeproof (H. A. Douglas Mfg. Co. No. 53295)	1	
	9 x 17-C	52131	Screw No. 8-32 x 1/4" Rd. Hd. (H. A. Douglas Mfg. Co. No. 50033)	6	
	14403	A-1350	Lockwasher No. 8 Keyed (H. A. Douglas Mfg. Co. No. 51104)	6	
	14317	A-6387	Coupling socket cable assembly (Warner Electric Brake No. 3744)	1	
	Following (19) items included in A-6387 Assembly:				
	14447	A-6557	Coupling socket cable	1	
	Following (3) Wires included in A-6557 Assembly:				
	1—Coupling socket terminal "TL" to Trailer blackout switch terminal "T" Cable (Color Brown)				
	2—Coupling socket terminal "SL" to Trailer blackout switch terminal "S" Cable (Color white)				
	3—Vehicle ground to trailer ground cable (Color red)				
	14448	A-6558	Coupling socket cable plug	1	
	14453	307556	Terminal (Warner Elect. Brake No. 110819)	3	
	14454	A-6640	Insulator sleeve (Warner Elect. Brake No. 110427)	2	
	14455	A-6533	Terminal (Warner Elect. Brake No. 110907)	3	
	14456	A-6641	Insulator (Warner Elect. Brake No. 110919)	3	
	14457	A-6644	Cable clamp (No. 3 wire) (Warner Elect. Brake No. 110885)	1	
	9 x 20	53063	Screw No. 6-32 x 3/4"	1	
	32 x 2-R	53062	Nut No. 6-32	1	
	90 x 1	A-6639	Washer Plain (Warner Elect. Brake No. 110210)	1	
	14458	A-6645	Insulator (Warner Elect. Brake No. 110889)	1	
	14459	A-6642	Dust shield (Warner Elect. Brake No. 110920)	1	
	14461	A-6637	Plug end (Warner Elect. Brake No. 4952)	1	
	14462	A-6643	Contact clip (Warner Elect. Brake No. 110886)	4	
	14463	A-6638	Screw No. 8-32 (Warner Elect. Brake No. 110880-A)	4	
	32 x 3	6214	Nut No. 8-32	4	
	92 x 3	52754	Lockwasher No. 8 Shakeproof	4	
	14464	53004	Screw No. 6-32	2	
	92 x 2	52569	Lockwasher No. 6 Shakeproof	2	
	181 x 16	A-6335	Clip 1/2" (1/4" Hole) (Coupling socket cable to draw bar bracket)	1	
	9 x 1-R	51738	Screw Hex. Hd. 1/4"-20 x 3/8" (Clip-coupling socket cable)	1	
	91 x 6-R	52706	Lockwasher 1/4" (Clip-coupling socket cable)	1	
	181 x 16	A-6809	Clip 1/2" (3/32" Hole) (Coupling socket cable to "A" frame channel)	2	
	66 x 1-R	52993	Screw No. 10-3/8" Rd. Hd. P.K. (Sheet metal)	1	
	9 x 2-R	5113	Screw Rd. Hd. No. 10-24 x 1/2" (Clip coupling socket cable to "A" frame channel)	1	
	32 x 4-R	6352	Nut Hex. No. 10-24 Thd. (For coupling socket cable clip)	1	
	91 x 4-R	52221	Lockwasher No. 10 (For coupling socket cable clip)	1	
	14334	A-6338	Trailer wiring harness (4 wires in braided loom)	1	
	181 x 13	A-5450	Clip 7/16" (Trailer wiring harness to body)	2	
9 x 2-R	5113	Screw Rd. Hd. No. 10-24 x 1/2" (Trailer wiring harness clip to body)	3		
32 x 4-R	6352	Nut Hex. No. 10-24 thd. (Trailer wiring harness screw clip to body)	3		
91 x 4-R	52221	Lockwasher No. 10 (Clip screw nut-Trailer wiring harness to body)	3		
92 x 24-C	53023	Lockwasher No. 10 Internal-External (Trailer ground cable front gusset right) (G. M. No. 178532)	1		
14342	A-6339	Connector to blackout tail light cable—Left side	1		
14318	A-6340	Connector to blackout tail light cable—Right side	1		
181 x 4	A-5598	Clip 1/4" (Connector to blackout tail light—Left side)	3		
181 x 7	A-5449	Clip 3/16" (Connector to blackout tail light—Left side)	3		
9 x 3-R	5064	Screw Rd. Hd. Mach. No. 10-24 x 5/8" (Clips—Harness extension & connector to blackout tail light)	3		
32 x 4-R	6352	Nut Hex. No. 10-24 thd. (Clip screw harness extension & connector)	3		
91 x 4-R	52221	Lockwasher No. 10 (Clip screw harness extension & connector)	3		
14356	635985	3-Wire slip connector (Trailer wiring harness extension to blackout tail lamp connector)	1		
14353	662276	Grommet 5/8" (Wiring harness thru side member)	2		
14439	345961	Grommet 13/32" (Wiring harness thru cross member)	2		
<b>0608-Tail Lamp</b>					
(See page 10 for Illustration)					
0608	R-11544	A-1064	Tail and stop lamp assembly—Left (Corcoran Brown No. 60142) (Arrow Safety Device No. 40-L)	1	
	R-11540	A-1065	Tail and stop lamp assembly—Right (Corcoran Brown No. 60242) (Arrow Safety Device No. 40-R)	1	
	R-21379	A-1073	Housing sub assembly (Tail and stop lamp body) (Corcoran Brown No. CB-9212) (Arrow Safety Device No. 4010)	2	



Gov't Group No.	Bantam Part No.	Willys Part No.	Description	No. Req.
<b>0608-Tail Lamp (Cont.)</b>				
0608	R-21355	A-1074	Upper service unit assembly—Left (Corcoran Brown No. CB-9218) (Arrow Safety Device No. 4025) .....	1
	R-21356	A-1078	Upper service unit assembly—Right (Corcoran Brown No. CB-9234) (Arrow Safety Device No. 4034) .....	1
	R-21357	A-1075	Lower tail lamp unit assembly (Corcoran Brown No. CB-9225) (Arrow Safety Device No. 4017) .....	2
	R-21381	A-1076	Door—Left (Corcoran Brown No. CB-9231) (Arrow Safety Device No. 4038) .....	1
	R-21380	A-1079	Door—Right (Corcoran Brown No. CB-9232) (Arrow Safety Device No. 4032) .....	1
	R-21382	A-1077	Door screw (Corcoran Brown No. CB-9233) (Arrow Safety Device No. 4033) .....	2
	32 x 7-R	5790	Nut ¼"-20 thd. Hex. (Tail lamp to bracket) .....	4
	92 x 86	53024	Lockwasher ¼" (Internal-external) (Between lamp and bracket for ground) (G. M. No. 174916) .....	4
	91 x 6-R	52706	Lockwasher ¼" (Tail lamp to bracket) .....	4
	14084	A-1306	Reflex reflector (Corcoran Brown No. 3121441) .....	4
	9 x 16	52834	Screw ¼"-28 x ½" Rd. Hd. (For reflex reflector) .....	8
	31 x 1	5914	Nut ¼"-28 (For reflex reflector) .....	8
		A-6372	Washer ¼" x ½" x ¼" .....	8
	91 x 6-R	52706	Lockwasher ¼" (For reflex reflector) .....	8
<b>1000-Axle Assembly</b>				
(See page 15 for Illustration)				
1000	14246	A-6823	Axle assembly .....	1
	14333	A-571	Spring clip plate and shaft assembly—Left (On right spring) .....	1
	14332	A-572	Spring clip plate and shaft assembly—Right (On left spring) .....	1
	14257	A-6511	Spring clip (Axle to spring) .....	4
	14421	A-6508	Nut Hex. ¼"-20 thd. Special (For spring clip) .....	8
	91 x 59-R	53044	Lockwasher ¼" Heavy duty (For spring clip) .....	8
<b>1200-Brake Assembly</b>				
(See page 13 for Illustration)				
1200	14321	A-6403	Brake assembly—Left (Bendix No. 46397) .....	1
	14320	A-6404	Brake assembly—Right (Bendix No. 46398) .....	1
	1 x 26-R	A-903	Brake disc screw (¾"-24 thd. x ⅞") .....	12
	31 x 3-R	636575	Brake disc screw nut (¾"-24 thd.) .....	12
	91 x 8-R	52046	Lockwasher ⅜" Std. (For brake disc screw) .....	12
<b>1201-Hand Brake</b>				
1201	14302	A-6378	Hand brake lever assembly—Complete .....	1
Following (1) item included in A-6378 Assembly:				
	14449	A-6474	Hand brake body .....	1
	14303	A-6376	Hand brake lever ratchet .....	1
	14304	A-6329	Hand brake lever pawl .....	1
	14443	A-6475	Hand brake lever pawl rod .....	1
	14444	A-6476	Hand brake lever pawl rod spring .....	1
	14445	A-6477	Hand brake lever pawl rod pin .....	1
	14446	A-6478	Hand brake lever pawl rod button .....	1
	1 x 8	5934	Screw ⅝"-24 x 1" Hex. Hd. (Hand brake lever to ratchet) .....	2
	1 x 43-R	6609	Screw ⅝"-24 x ⅞" Hex. Hd. (Pawl to hand brake lever) .....	1
	34 x 2-R	5910	Nut ⅝"-24 Hex. .....	2
	35 x 27-R	52891	Nut ⅝"-24 Stamped .....	2
	1 x 23-R	A-6025	Hand brake lever fulcrum bolt (⅜"-24 thd. x 1", Special) .....	1
	34 x 2-R	5781	Nut ⅝"-24 Hex., Castle (For hand brake lever fulcrum bolt) .....	1
	35 x 28-R	5020	Cotter pin ⅜" x ¼" (For hand brake lever fulcrum bolt) .....	1
	1 x 8-R	53050	Screw Hex. Hd. ⅝"-24 thd. x 1" (For hand brake ratchet) .....	2
	31 x 2-R	50802	Nut ⅝"-24 thd. Hex. (For hand brake ratchet bolt) .....	2
	91 x 7-R	53047	Lockwasher ⅝" Std. (For hand brake ratchet bolt) .....	2
	14305	A-6400	Hand brake lever rod .....	1
	90 x 6-R	53051	Washer plain (Hand brake rod to bell crank) .....	1
	115 x 31	5020	Cotter pin ⅜" x ¼" (Hand brake rod to bell crank) .....	2
	14306	A-6000	Hand brake bell crank .....	1
	14307	A-6517	Hand brake bell crank pivot pin .....	1
	33 x 78-R	53046	Nut ⅜"-24 thd. Hex., Castle (For bell crank pivot pin) .....	1
	115 x 32	5152	Cotter pin ⅜" x ⅞" (For bell crank pivot pin) .....	1
	14327	A-6768	Cable equalizer .....	1
	14328	A-6516	Cable hook bolt (Cable equalizer) .....	1
	31 x 2-R	50802	Nut Hex. ⅝"-24 thd. (For cable hook bolt) .....	2
	35 x 27-R	53049	Nut ⅝"-24 thd. Stamped (For cable hook bolt) .....	1
	14325	A-6406	Cable and conduit assembly .....	1
	14156	A-6766	Conduit to frame clip .....	2
	1 x 14-R	53048	Screw Hex. Hd. ⅝"-24 thd. x ¾" (Conduit to frame clip) .....	4
	31 x 2-R	50802	Nut Hex. ⅝"-24 thd. (Conduit to frame clip) .....	4
	91 x 7-R	53047	Lockwasher ⅝" Std. (Conduit to frame clip) .....	4
	14436	A-6526	Clevis pin (Cable end to cam lever) .....	2
	115 x 4	5067	Cotter pin (Cable end to cam lever pin) .....	2



Gov't Group No.	Bantam Part No.	Willys Part No.	Description	No. Req.
<b>1202-Shoes and Lining</b> (See page 15 for Illustration)				
1202	14359	116549	Brake shoe and lining assembly—Forward (Bendix No. 1141-S-5)	2
	14362	116550	Brake shoe and lining assembly—Reverse (Bendix No. 1141-S-6)	2
	14404	116600	Brake shoe lining and rivets service package (Bendix No. 44517) (Includes 2 forward, 2 reverse linings and 45 rivets to service two wheels)	1
	14440	374586	Rivets, tubular for brake lining (Bendix No. 179-S-6)	45
<b>1203-Brake Shoe Supporting Guide Springs, Adjusting Pins, Anchorage Plate</b> (See page 15 for Illustration)				
1203	14367	637899	Brake shoe anchor pin (Bendix No. 39953)	4
	14368	637900	Brake shoe anchor pin cam (Bendix No. 41876)	4
	14369	637901	Brake shoe anchor pin plate (Bendix No. 39956)	2
	14366	637902	Brake strut—Left (Bendix No. 41927)	1
	14365	637903	Brake strut—Right (Bendix No. 41928)	1
	31 x 5-R	637924	Anchor pin nut ½"-20 Hex. (Bendix No. 41708)	4
	14442	637923	Lockwasher ½" (For anchor pin) (Bendix No. 41665)	4
	14370	A-754	Brake shoe eccentric (Bendix No. 45771)	4
	31 x 53-C	A-755	Eccentric nut ¾"-24 (Bendix No. 30-S-3-K6)	4
	91 x 8-R	5010	Eccentric lockwasher ¾" (Bendix No. 40-S-33)	4
	14371	637905	Brake shoe return spring (Bendix No. 41545)	2
	14372	637906	Brake lever assembly (Bendix No. 41911)	2
<b>1208-Brake Dust Shield or Backing Plate</b> (See page 15 for Illustration)				
1208	14358	A-6458	Backing plate assembly—Left (Bendix No. 46423)	1
	14357	A-6459	Backing plate assembly—Right (Bendix No. 46424)	1
	1 x 46-R	6609	Screw 5/16"-24 x 1 ¼" (For conduit bracket on backing plate)	2
	31 x 2-R	50802	Nut 5/16"-24 Hex. (For conduit bracket on backing plate)	2
	91 x 107-R	51833	Lockwasher 5/16" (For conduit bracket on backing plate)	2
<b>1301-Wheel Assembly, Bearings, Retainers, Etc.</b> (See page 15 for Illustration)				
1301	14231	A-5467	Divided combat wheel assembly (16 x 4.50 rim) (Kelsey Hayes No. 25692)	2
	14232	A-5468	Inner half combat wheel (Kelsey Hayes No. 25693)	2
	14407	A-5549	Outer half combat wheel and bolt assembly (Kelsey Hayes No. 25917)	2
	14438	A-5472	Instruction plate (Kelsey Hayes No. 25696)	4
	14326	A-5470	Divided rim bolt (Kelsey Hayes No. 25695)	16
	14259	A-5471	Nut ¾" Hex. ½"-20 thd. (Rim bolt) (Kelsey Hayes No. 25779)	16
	14234	A-5488	Tire bead lock ring (16 x 6.00) (For .55" wide tire bead) (Kelsey Hayes No. 25807)	2
	14405	A-5986	Tire valve cap	2
	14406	A-5987	Tire mounting sleeve	2
<b>1302-Hubs and Drums, Wheel Studs and Nuts</b> (See page 15 for Illustration)				
1302	R-11023	A-1689	Hub and drum assembly—L.H. (Kelsey Hayes No. 25647)	1
	R-11022	A-1690	Hub and drum assembly—R.H. (Kelsey Hayes No. 25646)	1
	R-10111	A-1691	Hub assembly (Kelsey Hayes No. 25649)	2
	R-20731	A-472	Brake drum (Kelsey Hayes No. 24566)	2
	R-20051	A-473	Wheel hub bolt ½"-20 L.H. thd. (Kelsey Hayes No. 24569)	5
	R-20050	A-474	Wheel hub bolt ½"-20 R.H. thd.	5
	R-11023	A-475	Nut ½"-20 L.H. thd.	5
	R-11027	A-476	Nut Hex. ½"-20 R. H. thd.	5
	R-21159	52942	Cone and roller bearing (Timken No. 18590)	4
	R-21160	52943	Roller bearing cup (Timken No. 18520)	4
	R-21164	A-864	Hub oil seal assembly (Spicer No. 17004)	2
	R-21161	A-865	Outer wheel bearing washer (Spicer No. 17015)	2
	R-21162	A-866	Outer wheel bearing nut (Spicer No. 17016)	4
	R-21163	A-867	Outer wheel bearing nut lock washer (Spicer No. 17017)	2
	R-21031	A-904	Wheel flange gasket (Spicer No. 17146)	2
	14255	A-6038	Hub cap	2
	1 x 10-R	6299	Screw Hex. Hd. 3/8"-16 thd. x 7/8"	12
	91 x 8-R	52046	Lockwasher 3/8" (For hub cap)	12
<b>1506-Frame and Brackets</b>				
1506	1 x 57-R	53036	Screw Hex. Hd. ½"-20 thd. x 1 ½" ("A" frame channel to socket) (G.M. No. 123614)	4
	31 x 5-R	50811	Nut Hex. ½"-20 thd. ("A" frame channel to frame)	4
	91 x 10-R	53045	Lockwasher ½" Std. ("A" frame channel to frame)	4
	14331	A-6027	"A" Frame clamp—Left	1
	14330	A-6028	"A" Frame clamp—Right	1
	1 x 12-R	50847	Screw Hex. Hd. 3/8"-24 thd. x 1" ("A" frame clamp—Left and right) (G.M. No. 118591)	4
	31 x 3-R	50922	Nut Hex. 3/8"-24 thd. ("A" frame clamp screw) (G.M. No. 114942)	4
	91 x 8-R	52046	Lockwasher 3/8" Std. ("A" frame clamp screw)	4
	14269	A-6466	Draw bar bracket and plunger assembly	1
	14073	A-6009	Plunger handle and sleeve assembly	1
	14070	A-6010	Plunger spring (For draw bar bracket)	1
	62 x 2	53035	Set screw ¼"-20 x 3/4" headless (G.M. No. 102379)	1
	14338	392909	Alemite fitting—Straight threaded drive type (Alemite Corp. No. 1720)	1



Gov't Group No.	Bantam Part No.	Willys Part No.	Description	No. Req.
<b>1506-Frame and Brackets (Cont.)</b>				
1506	14228	A-6371	Support bracket.....	1
	14235	A-6519	Screw Hex. Hd. ¼"-18 thd. x 3¾" (Support bracket to draw bar bracket pivot bolt)...	1
	33 x 83-R	53039	Nut ¼"-18 thd., Hex. Castle (For pivot bolt) (G.M. No. 125280).....	1
	115 x 60	5108	Cotter pin ½" x 1¼" (For pivot bolt).....	1
	14229	A-6368	Support leg.....	1
	14340	A-6527	Screw Hex. Hd. ½"-20 thd. x 1¼" (Support leg to support bracket).....	2
	33 x 80-R	53040	Nut ½"-20 thd., Hex. Castle (Support leg to body) (G.M. No. 125370).....	2
	115 x 58	5137	Cotter pin ½" x 1" (Support leg to body).....	2
	14220	A-6518	Screw Hex. Hd. ¼"-20 thd. x 1" ("A" frame to draw bar bracket).....	4
	33 x 79-R	53041	Nut Hex. Castle ¼"-20 thd. ("A" frame to draw bar bracket screw) (G.M. No. 125361).....	4
	115 x 31	5021	Cotter pin ¾" x ¾" "A" frame to draw bar bracket screw).....	4
	14263	A-4005	Spring pivot bracket—Front.....	2
	14264	A-6448	Spring pivot bracket brace—Front.....	2
	100 x 4	5215	Rivet ⅜" x ⅜" Rd. Hd.....	4
	1 x 12-R	50847	Screw ⅜"-24 x 1" Hex. Hd. (Spring pivot bracket to frame) (G.M. No. 118591).....	8
	31 x 3-R	50922	Nut ⅜"-24 Hex. (G.M. No. 114942).....	8
	35 x 28-R	52909	Nut ⅜"-24 Stamped.....	8
	14395	A-6449	Spring shackle bracket and brace assembly—Rear—Left.....	1
	14394	A-6455	Spring shackle bracket and brace assembly—Rear—Right.....	1
	100 x 4	5215	Rivet ⅜" x ⅜" Rd. Hd. (Brace to bracket).....	4
	14282	A-6392	Safety chain.....	2
	14469	A-6393	Safety chain eye bolt.....	2
	31 x 30	6163	Nut ½"-13 Hex.....	2
	91 x 60	5009	Lockwasher ½".....	2
	14222	A-6515	Screw Hex. Hd. ¼"-16 thd. x 4" (Safety chain to draw bar bracket).....	1
	33 x 83-R	53039	Nut ¼"-16 thd., Hex. Castle (Safety chain to draw bar bracket screw) (G.M. No. 125280).....	1
	115 x 60	5108	Cotter pin ½" x 1¼" (Safety chain to draw bar bracket screw).....	1
	14280	A-6370	Lunette eye.....	1
	14299	A-6375	Lunette eye spring.....	1
	14298	A-6388	Lunette spring washer.....	2
	14301	A-6389	Lunette spring washer (Toungued).....	1
	33 x 84-R	53052	Draw bar eye nut ⅜"-14 slotted (For Lunette eye) (G.M. No. 123072).....	1
	115 x 89	50255	Cotter pin ½" x 1¼" (For Lunette eye).....	1
	14316	A-6377	Axle bumper.....	2
	1 x 21-R	53042	Screw Hex. Hd. ¼"-18 thd. x ¾".....	4
	31 x 27-R	53037	Nut Hex. ¼"-18 thd. (G.M. No. 118614).....	4
	91 x 7-R	53047	Lockwasher ¼" Std. (G.M. No. 116120).....	4
<b>1601-Springs</b>				
(See page 19 for Illustration)				
1601	14268	A-612	Spring assembly (8 leaves).....	2
For	14375	A-612	No. 1 Spring leaf.....	2
For	14376	A-612	No. 2 Spring leaf.....	2
For	14377	A-612	No. 3 Spring leaf.....	2
For	14378	A-612	No. 4 Spring leaf.....	2
For	14379	A-612	No. 5 Spring leaf.....	2
For	14380	A-612	No. 6 Spring leaf.....	2
For	14381	A-612	No. 7 Spring leaf.....	2
For	14382	A-612	No. 8 Spring leaf.....	2
	14383	359039	Spring eye bushing.....	2
	14384	116609	Spring center bolt.....	2
	31 x 2-R	50802	Spring center bolt nut.....	2
	14385	116458	Spring clip—Small.....	4
	14386	116460	Spring clip—Large.....	4
<b>1602-Shackles and Spring Attaching Parts</b>				
(See page 20 for Illustration)				
1602	14270	A-6776	Spring bolt—Front.....	2
	33 x 81-R	53043	Nut—Castellated ⅜"-18 thd.....	2
	115 x 33	5021	Cotter pin ½" x 1".....	2
	14338	392909	Alemite straight grease fitting (Alemite Corp. No. 1720).....	2
	14313	A-513	Spring shackle "U" bolt—L.H. thd. (For right spring—Rear end).....	1
	14312	A-514	Spring shackle "U" bolt—R.H. thd. (For left spring—Rear end).....	1
	14315	635532	Spring shackle bushing assembly—L.H. thd. (For right spring—Rear end).....	1
	14314	634432	Spring shackle bushing assembly—R.H. thd. (For right spring—Frame end).....	1
	14314	634432	Spring shackle bushing assembly—R.H. thd. (For spring and frame—Rear end—Left).....	2
	14408	A-515	Spring shackle grease seal.....	4
	14409	A-1252	Spring shackle grease seal retainer.....	4
<b>1603-Shock Absorbers</b>				
(See page 19 for Illustration)				
1603	14297	A-169	Shock absorber assembly.....	2
	R-10246	637936	Shock absorber bushing.....	8
	R-10247	A-6510	Special washer (For shock absorber).....	4
		52946	Cotter pin ½" x 1" (Shock absorber)—use on Willys only.....	4
	31 x 5-R		Nut ½"-20 Hex.—use on Bantam only.....	4
	91 x 110-R		Lockwasher ½"—use on Bantam only.....	4



Gov't Group No.	Bantam Part No.	Willys Part No.	Description	No. Req.
<b>1701-Fenders</b>				
1701	14245	A-4179	Fender assembly.....	2
	14237	A-3997	Fender anchor bracket.....	12
	1 x 56-R	53031	Bolt Hex. Hd. 3/8"-16 x 3/4" (Fender to body) (Rust proof).....	12
	31 x 28-R	53033	Nut Hex. 3/8"-16 Rust proof (Fender to body) (G.M. No. 123228).....	12
	90 x 7-R	53032	Washer 3/8" plain—Rust proof (Fender to body) (G.M. No. 118775).....	24
	91 x 8-R	52046	Lockwasher 3/8" Rust proof (Fender to body).....	12
<b>1800-Body and Attaching Parts</b>				
1800	14319	A-3977	Body assembly, only, painted.....	1
	14300	A-3978	Body—Complete.....	1
	14236	A-3986	Hook (8 reqd. Tarpaulin rope to side panels; 1 reqd. tarpaulin rope hook to rear panels; 2 reqd. tarpaulin rope hook to front panels).....	11
	14435	A-4109	Body drain hole valve assembly.....	1
	14434	A-4105	Body drain hole valve support.....	1
	9 x 19-R	52236	Screw No. 10-32 x 3/8" Rd. Hd. (Body drain hole valve support to attaching bracket) GM-124191.....	2
	92 x 4-R	53053	Lockwasher No. 10 (External).....	2
	14346	A-4062	Drain hole ball seat.....	1
	14399	A-4058	Tail lamp bracket—Left.....	1
	14398	A-4072	Tail lamp bracket—Right.....	1
	100 x 5	50769	Rivet Rd. Hd. 3/8" x 3/4" (Cross member and gussets to side member).....	8
	100 x 5	50769	Rivet Rd. Hd. 3/8" x 3/4" (Cross member to side member).....	4
	14275	A-4017	Frame draw bar socket—Left.....	1
	14274	A-4018	Frame draw bar socket—Right.....	1
	100 x 6	5215	Rivet Rd. Hd. 3/8" x 1" (Frame bar socket to cross member).....	2
	100 x 5	50769	Rivet Rd. Hd. 3/8" x 3/4" (Frame draw bar socket to side member).....	8
	14243	A-4015	Shock absorber mounting bracket assembly.....	2
	100 x 5	50769	Rivet Rd. Hd. 3/8" x 3/4" (Shock absorber mounting bracket to side member).....	4
	14260	A-4048	Tarpaulin assembly—Complete.....	1
	14291	A-4022	Eyelet 1/2" No. 4 (Tarpaulin).....	14
	14292	A-4023	Washer Eyelet 1/2" No. 4 (Tarpaulin).....	14
	14427	A-4045	Tarpaulin anchor rope assembly.....	10
	14336	A-3979	Ring fastener (Tarpaulin anchor ropes).....	20
<b>2202-Identification and Caution Plates</b>				
2202	14348	A-6431	Name plate.....	1
	105 x 2	52613	Name plate rivet 3/4" x 3/16" Oval head—Tubular.....	4



# NUMERICAL INDEX

Bantam Part No.	Willys Part No.	Description	Gov't Group No.	List
R-10111	A-1691	Hub Assembly	1302	\$ 6.00
R-10246	637936	Bushing	1603	.10
R-10247	A-6510	Washer, Special	1603	.02
R-11022	A-1690	Hub and Drum	1302	8.60
R-11023	A-1689	Hub and Drum	1302	8.60
R-11027	A-476	Nut	1302	.05
R-11028	A-475	Nut	1302	.05
R-11540	A-1065	Lamp	0608	8.32
R-11544	A-1064	Lamp	0608	8.08
14070	A-6010	Spring	1506	.04
14073	A-6009	Handle and Sleeve	1506	1.00
14084	A-1306	Reflector	0608	.90
14156	A-6766	Clip	1201	.05
14220	A-6518	Screw	1506	.05
14222	A-6515	Screw	1506	.28
14228	A-6371	Bracket	1506	6.00
14229	A-6368	Leg, Support	1506	3.60
14231	A-5467	Wheel, Combat	1301	4.01
14232	A-5468	Wheel, Combat — Inner	1301	3.78
14234	A-5488	Ring, Lock	1301	2.16
14235	A-6519	Screw	1506	.25
14236	A-3986	Hook	1800	.10
14237	A-3997	Bracket	1701	.10
14243	A-4015	Bracket	1800	1.00
14245	A-4179	Fender	1701	2.56
14246	A-6823	Axle	1000	33.20
14255	A-6038	Cap, Hub	1302	.10
14257	A-6511	Clip, Spring	1000	.36
14259	A-5471	Nut	1301	.05
14260	A-4048	Tarpaulin	1800	POA
14263	A-4005	Bracket	1506	.60
14264	A-6448	Brace	1506	.12
14268	A-612	Spring	1601	5.15
14269	A-6466	Bracket and Plunger	1506	10.40
14270	A-6776	Bolt	1602	.25
14274	A-4018	Socket, Right	1800	.65
14275	A-4017	Socket, Left	1800	.65
14276	A-6021	Switch	0606	1.36
14280	A-6370	Eye, Lunette	1506	12.00
14282	A-6392	Chain	1506	1.45
14291	A-4022	Eyelet	1800	Doz. .07
14292	A-4023	Washer	1800	Doz. .07
14297	A-169	Absorber, Shock	1603	3.75
14298	A-6388	Washer	1506	.05
14299	A-6375	Spring	1506	.60
14300	A-3978	Body	1800	POA
14301	A-6389	Washer	1506	.05
14302	A-6378	Lever	1201	3.13
14303	A-6376	Ratchet	1201	.60
14304	A-6329	Pawl, Hand Brake	1201	.40
14305	A-6400	Rod	1201	.24
14306	A-6000	Crank	1201	.16
14307	A-6517	Pin, Pivot	1201	.35
14312	A-514	Bolt, "U"	1602	.50
14313	A-513	Bolt, "U"	1602	.50
14314	634432	Bushing	1602	.30
14315	635532	Bushing	1602	.30
14316	A-6377	Bumper, Axle	1506	.25
14317	A-6387	Cable	0606	8.70
14318	A-6340	Cable	0606	.60
14319	A-3977	Body	1800	POA
14320	A-6404	Brake	1200	20.00
14321	A-6403	Brake	1200	20.00
14325	A-6406	Cable and Conduit	1201	3.00
14326	A-5470	Bolt	1301	.10
14327	A-6768	Equalizer, Cable	1201	.10
14328	A-6516	Bolt, Cable Hook	1201	.15
14330	A-6028	Clamp	1506	.25
14331	A-6027	Clamp	1506	.25
14332	A-572	Plate and Shaft Assy. — Right	1000	1.68
14333	A-571	Plate and Shaft Assy. — Left	1000	1.68
14334	A-6338	Harness, Wiring	0606	3.05
14336	A-3979	Fastener, Ring	1800	Doz. .05
14338	392909	Fitting	1506	.03
14338	392909	Fitting	1602	.03
14340	A-6527	Screw	1506	.08

All Prices Subject to Change Without Notice.

Part Numbers with the prefix letter (R) are also used on the American Bantam ¼-ton Truck Model BRC.



Bantam Part No.	Willys Part No.	Description	Gov't Group No.	List
14342	A-6339	Cable.....	0606	1.25
14346	A-4062	Seat, Ball.....	1800	.15
14348	A-6431	Plate, Name.....	2202	.20
14353	662276	Grommet.....	0606	.04
14356	635985	Connector.....	0606	.06
14357	A-6459	Plate, Backing.....	1208	3.30
14358	A-6458	Plate, Backing.....	1208	3.30
14359	116549	Shoe and Lining.....	1202	1.25
14362	116550	Shoe and Lining.....	1202	1.25
14365	637903	Strut, Brake.....	1203	.24
14366	637902	Strut, Brake.....	1203	.24
14367	637899	Pin, Anchor.....	1203	.15
14368	637900	Cam.....	1203	.10
14369	637901	Plate, Anchor Pin.....	1203	.10
14370	A-754	Eccentric.....	1203	.15
14371	637905	Spring.....	1203	.09
14372	637906	Lever.....	1203	.70
14375	For A-612	Leaf, Spring No. 1.....	1601	1.00
14376	For A-612	Leaf, Spring No. 2.....	1601	1.10
14377	For A-612	Leaf, Spring No. 3.....	1601	.70
14378	For A-612	Leaf, Spring No. 4.....	1601	.65
14379	For A-612	Leaf, Spring No. 5.....	1601	.60
14380	For A-612	Leaf, Spring No. 6.....	1601	.50
14381	For A-612	Leaf, Spring No. 7.....	1601	.35
14382	For A-612	Leaf, Spring No. 8.....	1601	.30
14383	359039	Bushing.....	1601	.32
14384	116609	Bolt.....	1601	.10
14385	116458	Clip, Small.....	1601	.20
14386	116460	Clip, Large.....	1601	.20
14394	A-6455	Bracket and Brace.....	1506	2.28
14395	A-6449	Bracket and Brace.....	1506	2.28
14398	A-4072	Bracket, Right.....	1800	.15
14399	A-4058	Bracket, Left.....	1800	.15
14400	A-6539	Gasket, Cover.....	0606	.07
14401	A-6538	Plate, Cover.....	0606	.10
14402	A-6540	Nut.....	0606	.16
14403	A-1350	Lockwasher.....	0606	.01
14404	116600	Lining and Rivets.....	1202	3.00
14405	A-5986	Cap, Valve.....	1301	.03
14406	A-5987	Sleeve.....	1301	.18
14407	A-5549	Wheel, Combat — Outer.....	1301	3.25
14408	A-515	Seal.....	1602	.05
14409	A-1252	Retainer.....	1602	.04
14421	A-6508	Nut.....	1000	.03
14427	A-4045	Rope, Anchor.....	1800	.90
14434	A-4105	Support, Valve.....	1800	.20
14435	A-4109	Valve Assembly.....	1800	.90
14436	A-6526	Pin, Clevis.....	1201	.01
14438	A-5472	Plate, Instruction.....	1301	.05
14439	345961	Grommet.....	0606	.05
14440	374586	Rivet.....	1202	Doz. .07
14442	637923	Lockwasher.....	1203	.01
14443	A-6475	Rod, Hand Brake Pawl.....	1201	.15
14444	A-6476	Spring, Pawl Rod.....	1201	.05
14445	A-6477	Pin, Pawl Rod.....	1201	.02
14446	A-6478	Button, Pawl Rod.....	1201	.45
14447	A-6557	Cable, Coupling Socket.....	0606	3.75
14449	A-6474	Body, Hand Brake.....	1201	1.15
14453	307556	Terminal.....	0606	.02
14454	A-6640	Sleeve, Insulator.....	0606	3.00
14455	A-6533	Terminal.....	0606	Doz. .05
14456	A-6641	Insulator.....	0606	.02
14457	A-6644	Clamp, Cable.....	0606	.10
14458	A-6645	Insulator.....	0606	.05
14459	A-6642	Shield, Dust.....	0606	.05
14448	A-6558	Plug, Coupling Socket.....	0606	5.00
14461	A-6637	Plug, End.....	0606	1.45
14462	A-6643	Clip, Contact.....	0606	.20
14463	A-6638	Screw.....	0606	.04
14464	53004	Screw.....	0606	.02
R-20050	A-474	Bolt, Hub.....	1302	.05
R-20051	A-473	Bolt, Hub.....	1302	.05
R-20731	A-472	Drum, Brake.....	1302	3.25
R-21031	A-904	Gasket.....	1302	.05
R-21159	52942	Cone.....	1302	3.21
R-21160	52943	Cup.....	1302	2.04
R-21161	A-865	Washer.....	1302	.08
R-21162	A-866	Nut.....	1302	.25

All Prices Subject to Change Without Notice.

Part Numbers with the prefix letter (R) are also used on the American Bantam ¼-ton Truck Model BRC.



Bantam Part No.	Willys Part No.	Description	Gov't Group No.	List
R-21163	A-867	Lockwasher	1302	.05
R-21164	A-864	Seal	1302	.55
R-21355	A-1074	Service Unit	0608	2.48
R-21356	A-1078	Service Unit	0608	2.88
R-21357	A-1075	Service Unit	0608	3.20
R-21379	A-1073	Housing	0608	1.46
R-21380	A-1079	Door — Right	0608	.60
R-21381	A-1076	Door — Left	0608	.60
R-21382	A-1077	Screw	0608	.09
1 x 21-R	53042	Screw	1506	.02
1 x 8-R	5934	Screw	1201	.02
1 x 12-R	A-6025	Bolt	1201	.04
1 x 23-R	50847	Screw	1506	.04
1 x 14-R	53048	Screw	1201	.02
1 x 26-R	A-903	Screw	1200	.03
1 x 12-R	50847	Screw	1506	.03
1 x 10-R	6299	Screw	1302	.02
1 x 43-R	6609	Bolt	1201	.04
1 x 46-R	6609	Screw	1208	.03
1 x 56-R	53031	Bolt	1701	.02
1 x 57-R	53036	Screw	1506	.05
9 x 1-R	51738	Screw	0606	.02
9 x 2-R	5113	Screw	0606	Doz. .05
9 x 3-R	5064	Screw	0606	Doz. .06
9 x 16	52834	Screw	0608	Doz. .08
9 x 17-C	52131	Screw	0606	Doz. .04
9 x 18-C	53055	Screw	0606	.01
9 x 19-R	52236	Screw	1800	Doz. .10
9 x 20	53063	Screw	0606	.02
31 x 1	5914	Nut	0608	.01
31 x 2-R	50802	Nut	1201	.01
31 x 2-R	50802	Nut	1208	.01
31 x 3-R	636575	Nut	1200	.01
31 x 3-R	50922	Nut	1506	.01
31 x 5-R	637924	Nut	1203	.05
31 x 5-R	50811	Nut	1506	.05
31 x 5-R		Nut	1603	.05
31 x 2-R	50802	Nut	1601	.01
31 x 27-R	53037	Nut	1506	.02
31 x 28-R	53033	Nut	1701	.02
31 x 52-R	5910	Nut	1202	.04
31 x 53-C	A-755	Nut, Eccentric	1203	.02
31 x 53-R	5781	Nut	1201	.01
32 x 2-R	53062	Nut	0606	.02
32 x 3	6214	Nut	0606	.03
32 x 4-R	6352	Nut	0606	Doz. .03
32 x 5	52216	Nut	0606	Doz. .08
32 x 7-R	5790	Nut	0608	Doz. .06
33 x 78-R	53046	Nut	1201	.01
33 x 79-R	53041	Nut	1506	.02
33 x 80-R	53040	Nut	1506	.03
33 x 81-R	53043	Nut	1602	.05
33 x 83-R	53039	Nut	1506	.12
33 x 84-R	53052	Nut	1506	.15
35 x 27-R	52891	Nut	1201	.01
35 x 28-R	52909	Nut	1506	.01
62 x 2	53035	Screw	1506	.02
66 x 1-R	52993	Screw	0606	Doz. .07
90 x 1	A-6639	Washer	0606	.02
90 x 6-R	53051	Washer	1201	Doz. .08
90 x 7-R	53032	Washer	1701	Doz. .05
91 x 4-R	52221	Lockwasher	0606	Doz. .01
91 x 6-R	52706	Lockwasher	0606	Doz. .02
91 x 6-R	52706	Lockwasher	0608	Doz. .02
91 x 7-R	53047	Lockwasher	1201	Doz. .02
91 x 7-R	53047	Lockwasher	1506	Doz. .02
91 x 8-R	52046	Lockwasher	1200	.01
91 x 8-R	5010	Lockwasher	1203	.01
91 x 8-R	52046	Lockwasher	1302	.01
91 x 8-R	52046	Lockwasher	1506	.01
91 x 8-R	52046	Lockwasher	1701	.01
91 x 10-R	53045	Lockwasher	1506	Doz. .06
91 x 59-R	53044	Lockwasher	1000	Doz. .08
91 x 107-R	51833	Lockwasher	1208	.01
91 x 110-R		Use Bantam Part No. 14442. (This applies only to the item in Gov't Group No. 1203)		
91 x 110-R		Lockwasher	1603	Doz. .10
92 x 2	52569	Lockwasher	0606	.02

All Prices Subject to Change Without Notice.

Part Numbers with the prefix letter (R) are also used on the American Bantam ¼-ton Truck Model BRC.



## ¼ TON TWO WHEEL GOVERNMENT TRAILER

Bantam Part No.	Willys Part No.	Description	Gov't Group No.		List
92 x 3	52754	Lockwasher.....	0606	Doz.	.03
92 x 4-R	53053	Lockwasher.....	1800		.02
92 x 24-R	52859	Lockwasher.....	0606	Doz.	.08
92 x 36	53054	Lockwasher.....	0606		.09
92 x 86	53024	Lockwasher.....	0608		.01
92 x 24-C	53023	Lockwasher.....	0606	Doz.	.06
100 x 4	5215	Rivet.....	1506		.01
100 x 5	50769	Rivet.....	1800	Doz.	.15
100 x 6	5215	Rivet.....	1800		.01
105 x 2	52613	Rivet.....	2202	Doz.	.06
115 x 4	5067	Cotter Pin.....	1201	Doz.	.01
35 x 28-R	5020	Cotter Pin.....	1201	Doz.	.01
115 x 32	5152	Cotter Pin.....	1201	Doz.	.02
115 x 31	5021	Cotter Pin.....	1506	Doz.	.02
115 x 33	5021	Cotter Pin.....	1602	Doz.	.02
115 x 58	5137	Cotter Pin.....	1506	Doz.	.03
115 x 60	5108	Cotter Pin.....	1506	Doz.	.03
115 x 89	50255	Cotter Pin.....	1506	Doz.	.06
181 x 4	A-5598	Clip.....	0606	Doz.	.05
181 x 7	A-5449	Clip.....	0606		.03
181 x 13	A-5450	Clip.....	0606	Doz.	.10
181 x 16	A-6809	Clip.....	0606		.01

All Prices Subject to Change Without Notice.

Part Numbers with the prefix letter (R) are also used on the American Bantam ¼-ton Truck Model BRC.