

TM 9-1826A/TO 19-75CCA-6

*This manual supersedes TM 9-1826A, 11 February 1944*

---

ORDNANCE  
MAINTENANCE  
CARBURETORS  
(CARTER)

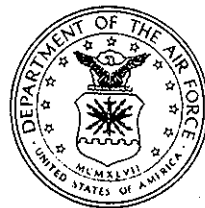

# CHAPTER 2

## BASIC PRINCIPLES OF OPERATION

---

### Section I. GENERAL

#### 6. Operating Conditions of Engine

The purpose of the carburetor is to supply the correct mixture of fuel and air for any and all conditions of speed and load imposed upon the engine. The engines of present day vehicles must be completely flexible in the speed range from approximately 500 rpm to more than 3,000 rpm. At any point in this range, the vehicle may be subjected to a comparatively light load or a very heavy load. It must adapt itself immediately to any change of load or speed imposed upon it, within the limits of its maximum power output.

#### 7. Requirements of Carburetion

It is well known that a mixture of gasoline and air will burn. However, a mixture which contains less than 8 pounds or more than 20 pounds of air to each pound of gasoline will not ignite. The ratio of the weight of air to the weight of gasoline in a mixture of the two is known as the "air-fuel ratio." Thus a mixture which contained 12 pounds of air for each pound of gasoline would be said to have an air-fuel ratio of 12:1. (Read "twelve to one.") Although any mixture between 8:1 and 20:1 will burn nevertheless the air-fuel ratio used for a gasoline engine must have a very definite value for each condition of engine operation. For maximum economy, a mixture of 16:1 air-fuel ratio is required. Mixtures which contain less gasoline are said to be "lean," those with more gasoline are known as "rich" mixtures. For idling conditions the mixture must be very rich (about 10:1), as the speed of the engine increases the mixture should become less rich until at about 20 mph the mixture should be 16:1. This is the ratio which will give best economy and should be maintained until a speed of about 50 mph is attained. As the speed is increased above 50 mph the mixture should become richer until at top speed the air-fuel ratio should be about 13:1. This is done in order to have the engine develop maximum power. For heavy pulling (high load) at lower speeds it is also desirable to supply a "power mixture." The primary function of the carburetor is to control the speed of the engine and at

the same time to vary the air-fuel ratio in accordance with the speed. In addition to this it has two other functions which will be described in the following paragraphs.

## Section II. THE FIVE CARBURETOR CIRCUITS

### 8. General

In order to meet the fuel requirements of an engine, five systems or circuits are used in the carburetor. These are the low-speed circuit, high-speed circuit, pump circuit, choke circuit, and float circuit. The low-speed circuit supplies all the fuel for speeds between idle and 20 mph and part of the fuel for speeds from 20 to 30 mph. The high-speed circuit supplies part of the fuel required for speeds from 20 to 30 mph and all of the fuel for speeds higher than this. The pump circuit supplies a small additional supply of fuel for periods of acceleration in order to prevent faltering of the engine. The purpose of the choke is to provide the means of supplying a very rich mixture for starting purposes. A supply of gasoline for the high-speed circuit, low-speed circuit and pump circuit is maintained in the carburetor by the float circuit. These circuits are interdependent. Each must operate properly in order for the carburetor as a whole to give satisfactory service.

### 9. Low-Speed Circuit

*a. Development.* Figures 1 through 3 show successive steps in the development of the low-speed circuit. The engine, represented as a single cylinder and piston, acts like a vacuum pump and creates a low-pressure area under the nearly closed throttle valve. This low pressure pulls the gasoline up out of the fuel reservoir (bowl) (A of fig. 1). The restriction at the bottom of the tube (low-speed jet), below the surface of the gasoline, limits the rate at which gasoline may be drawn up. If this system were used, an almost solid stream of gasoline would be discharged into the intake manifold (A of fig. 1). B of figure 1 shows the methods used to atomize the gasoline so that a spray will be discharged. At a point in the tube, air is allowed to enter through a restriction (bypass); this breaks up the flow into alternate slugs of gasoline and air. Next the gasoline and air pass through a restriction (economizer) in the tube which breaks up the slugs of gasoline into fine droplets; further on in the tube, additional air is admitted through a restriction (idle-bleed-hole) to cause the gasoline droplets to break up still further so that a fine spray will be discharged into the manifold. Not all carburetors use the second air intake (idle-bleed hole) but the effect is much the same regardless of this. It should be noted that the ends of the tubes through which the air is admitted are restricted (B of fig. 1) in order

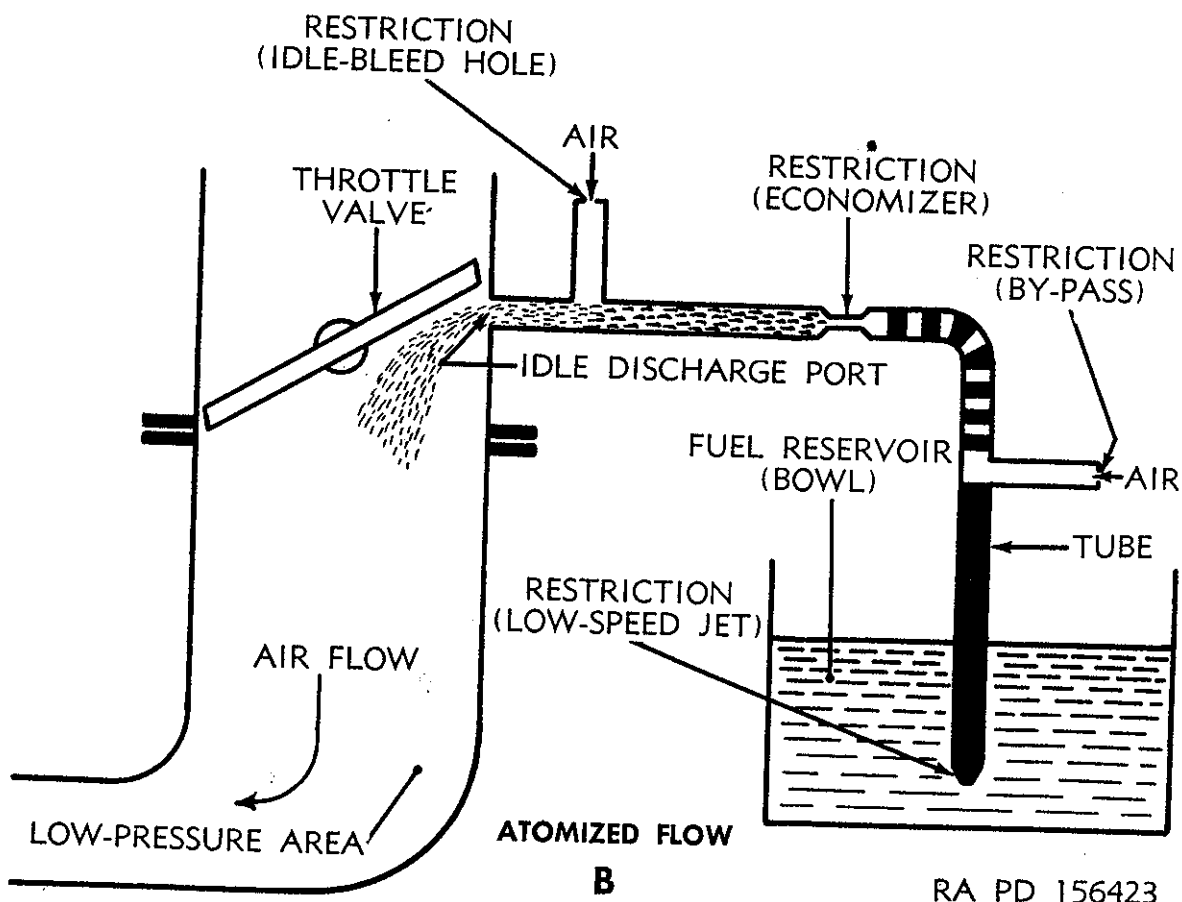
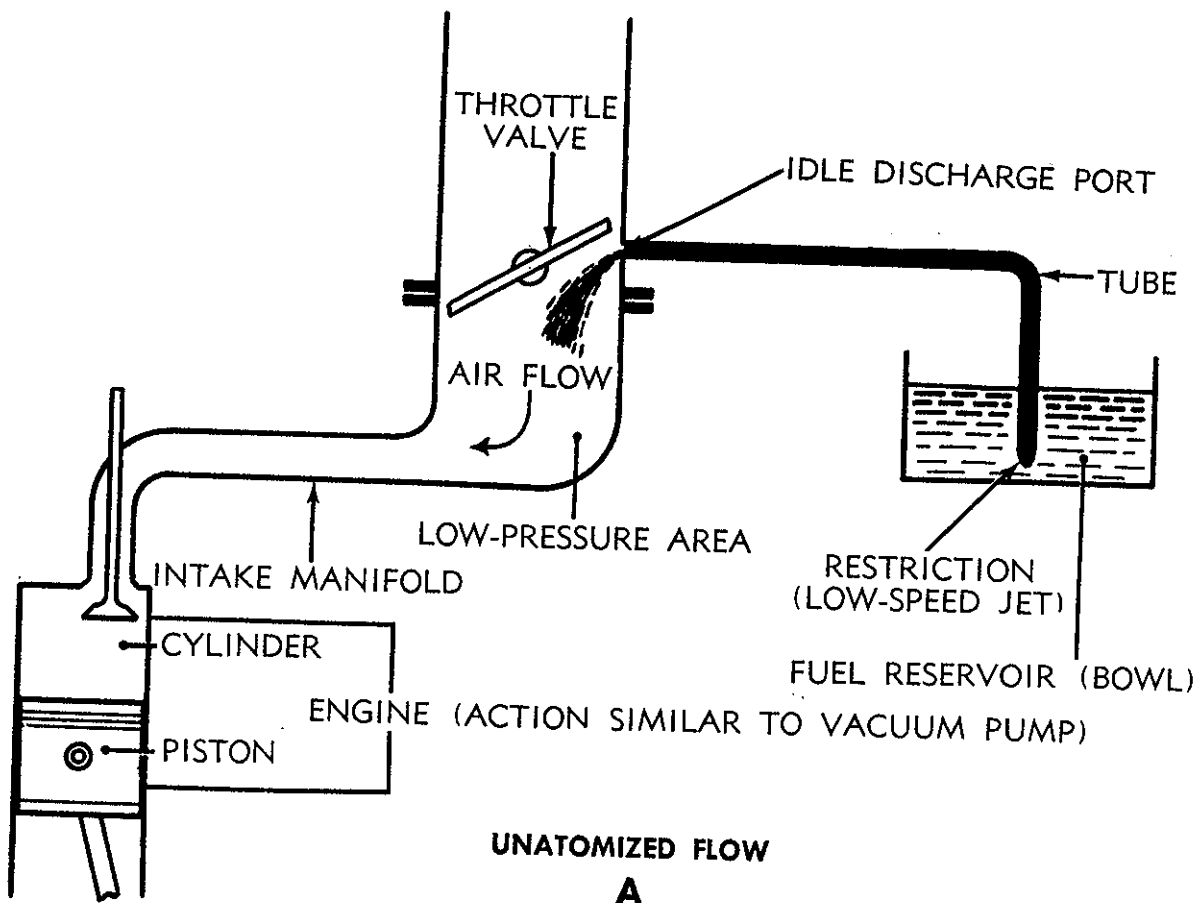

RA PD 156423

Figure 1. Development of low-speed system (constant flow).

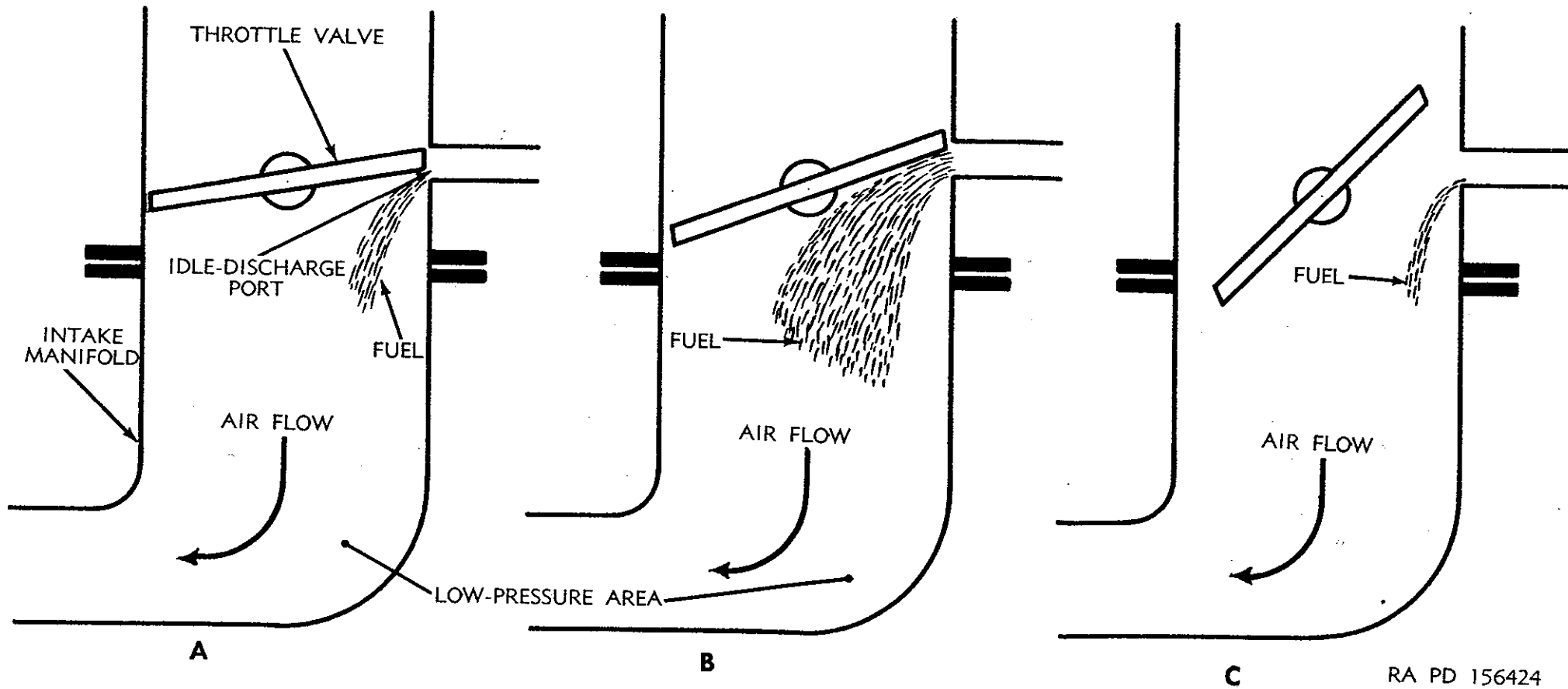

RA PD 156424

Figure 2. Development of low-speed system (variable flow).

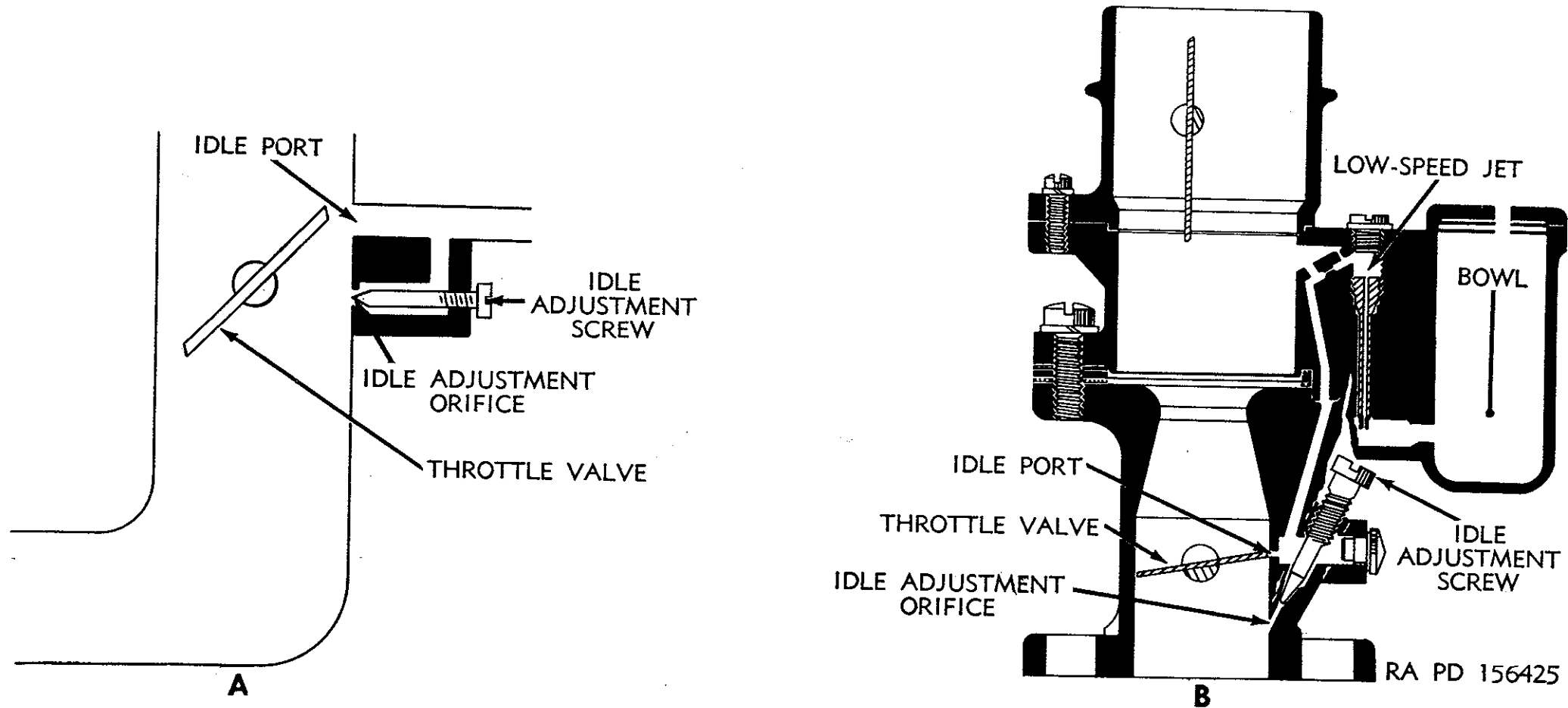

Figure 3. Development of low-speed system (variable flow with idle adjustment).

to limit the amount of air entering. At this point fuel has been admitted to the engine as a fine spray but there is no method of increasing the amount of fuel entering as the throttle is opened to admit more air and increase engine speed. This must be done in order that the correct air-fuel ratio may be maintained. In figure 2, the opening into the carburetor (idle-discharge port) has been elongated so that it is now in the shape of a slot. In A of figure 2, the throttle is almost closed and only a small portion of the slot is exposed to the low pressure below the throttle valve. As the throttle valve is opened (B of fig. 2), more air is admitted and more of the slot is exposed to the low pressure under the throttle valve. This permits a greater quantity of fuel to be discharged and maintains the correct air-fuel ratio. Various low speed delivery characteristics may be designed into the carburetor by changing the shape of the discharge port. Thus, some are rectangular, some are keyhole shaped, and still others employ two slots, one above the other. As the throttle valve is opened still further (C of fig. 2), the pressures above and below the throttle valve tend to equalize so that by the time a speed of about 30 mph is reached, there is no longer enough vacuum to cause any delivery from the low-speed circuit. The low-speed system as shown in figure 2 will work. However, in order to obtain a smooth idle, it is necessary to provide some method by which a fine adjustment of the idle mixture may be obtained. This is done by providing a second discharge opening the size of which may be varied by means of an adjustable orifice (idle adjustment orifice). This orifice is placed below the idle port. A of figure 3 shows the carburetor with this idle adjustable orifice. B of figure 3 shows a sketch of the low-speed circuit in an actual carburetor so that the form of the parts may be noted.

*b. Metering Characteristics.* The design of the low-speed circuit is such that at idle an air-fuel ratio of about 10:1 is attained, the proportion of gasoline continuously decreases until at 20 mph the 16:1 economy mixture is supplied. At speeds between 20 and 30 mph, the mixture supplied by the low-speed circuit alone will be too lean to run the engine properly.

## 10. High-Speed Circuit

*a. Requirements.* Since the low-speed circuit does not supply a rich enough mixture at speeds above 20 mph, it is necessary to design a high-speed circuit so that it will begin to deliver at that speed. It must be so constructed that the discharge will increase rapidly from 20 to 30 mph in order to supply the necessary fuel as the low-speed system drops out. At speeds from 30 to 50 mph, the rate of discharge must increase at a slower rate to maintain a 16:1 ratio as the rate of air flow increases. At speeds above 50 mph, the rate of fuel delivery must again increase at a rapid rate in order to supply the required power mixture.

*b. Principles of Operation.* The principle upon which the high-speed circuit operates is similar to that for the low-speed circuit in that both make use of a vacuum or low-pressure area to suck the gasoline into the carburetor. However, the high-speed circuit must discharge when the throttle is open and there is very little vacuum created by the engine. Consequently, some other method must be used to create the necessary low pressure. The device used to do this is known as a venturi tube (fig. 4). Air is shown flowing through the tube from left to right. As the air approaches the narrowest portion called the "throat," it is speeded up and the pressure drops. As the air passes through the expanding portion of the venturi, the pressure increases until at the end of this section the pressure is only slightly below that at the entrance to the tube. The pressures in the venturi tube are indicated by the heights of the liquid columns in the attached tubes. If several venturi tubes (fig. 5) are arranged so that the exit end of one is in the throat on the next, the drop in pressure in each tube will be passed on to the one inside it, as shown by the heights of the liquid columns. In this manner, a higher vacuum can be produced at the throat of the smallest venturi than could practically be produced if only a single venturi were used. Practical carburetors are in use which employ both single and multiple venturi systems. The venturi provides the means of creating the low pressure that is needed to cause fuel to flow into the venturi tube. Figure 6 shows the venturi installed in a carburetor. A simple nozzle extends from the fuel reservoir (bowl) into the throat section of the venturi. The bowl end has a restriction (high-speed jet) in it to limit rate at which the fuel can flow into the nozzle.

*c. Metering Characteristics.*

- (1) *Intermediate speed.* At speeds below 20 mph, the air does not flow through the venturi with enough speed to cause any discharge from the nozzle. At 20 mph the nozzle discharge begins and increases rapidly until a speed of 30 mph is reached. In this range (20 to 30 mph), both the low-speed and high-speed circuits are functioning. The two discharges combine with the entering air to give the required 16:1 ratio. At speeds above 30 mph only, the high-speed circuit functions. The characteristics of this simple system are such that an air-fuel ratio of 16:1 will be maintained at all speeds up to 30 mph.
- (2) *High speed.* Since the requirements of the engine demand that at speeds above 30 mph a richer mixture than 16:1 be supplied, it is necessary to incorporate some device into the high-speed circuit which will enrich the mixture at high speeds. Several devices may be used to accomplish this. One of them, the metering rod, is described here. Two others, the step-up jet and vacuumeter, are described later in the text



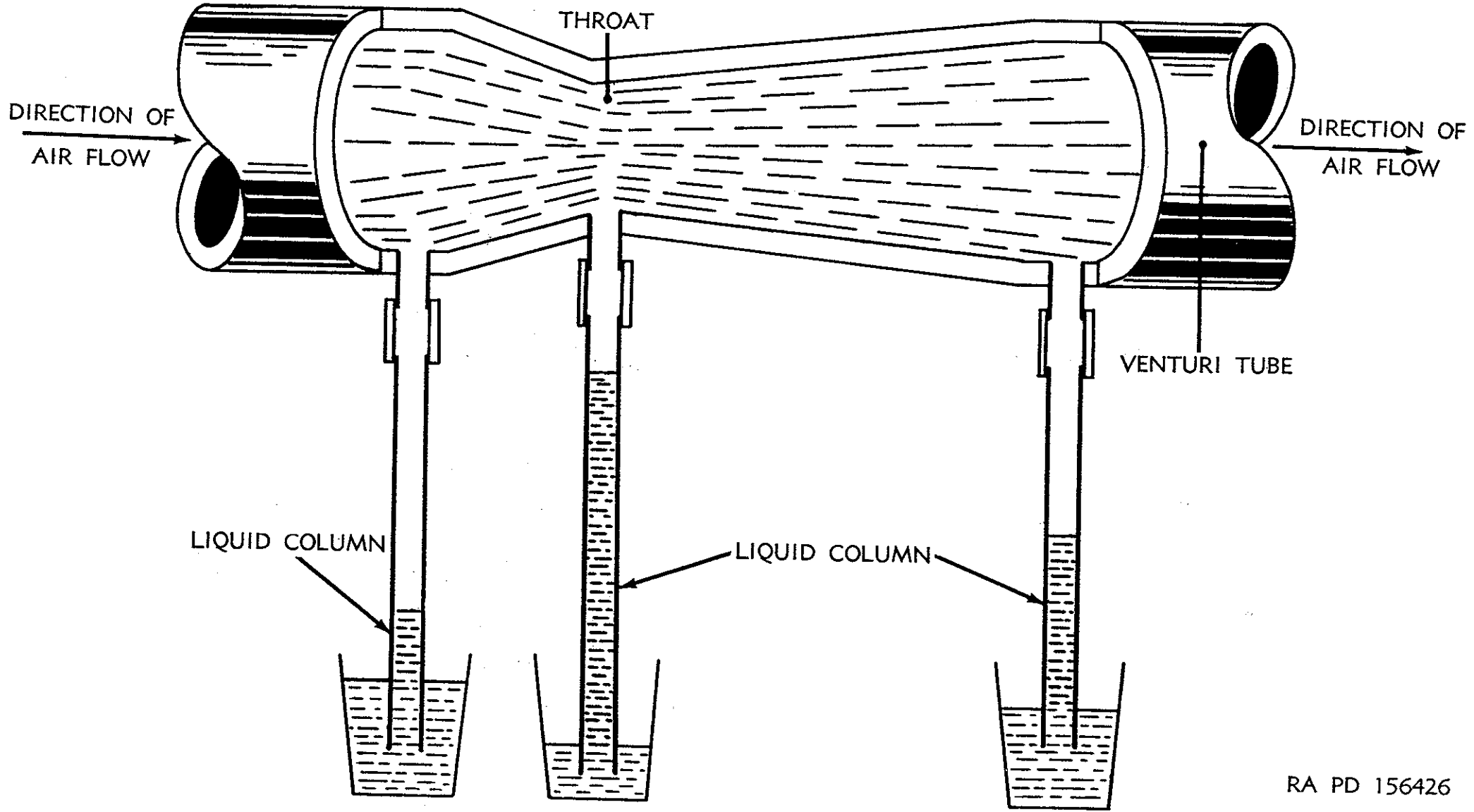

Figure 4. Action of air flowing through a venturi tube.

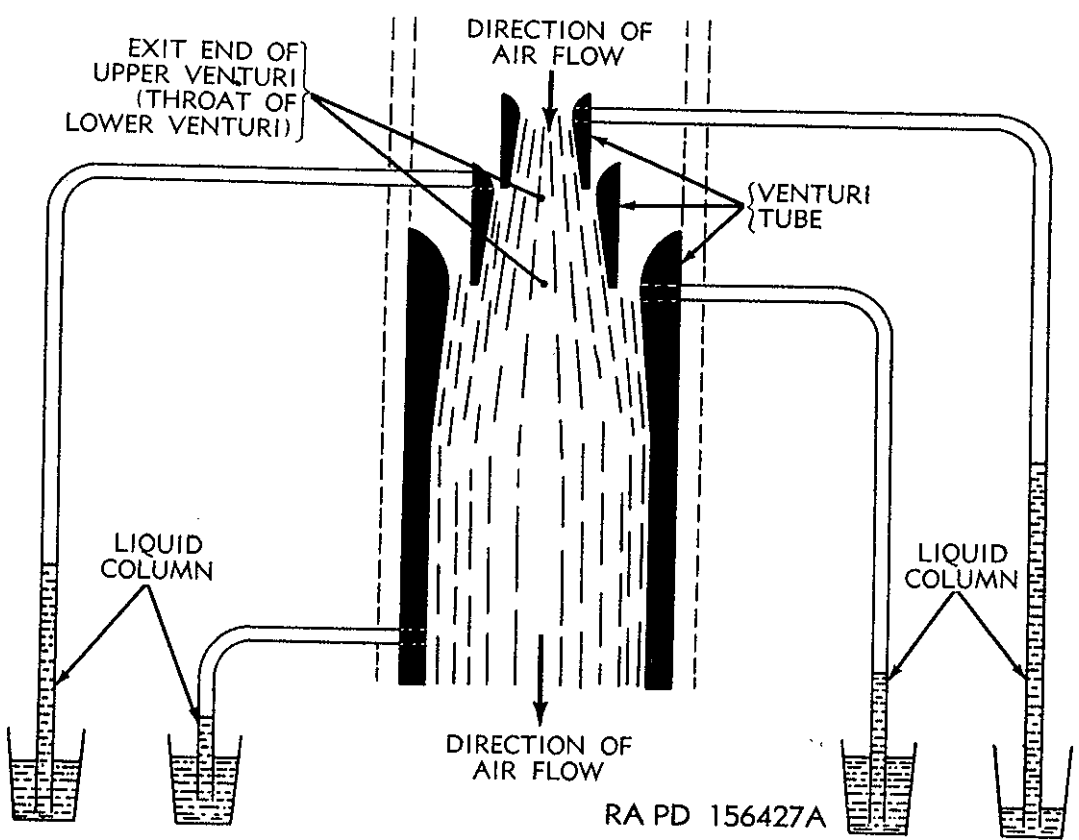

Figure 5. Triple venturi system.

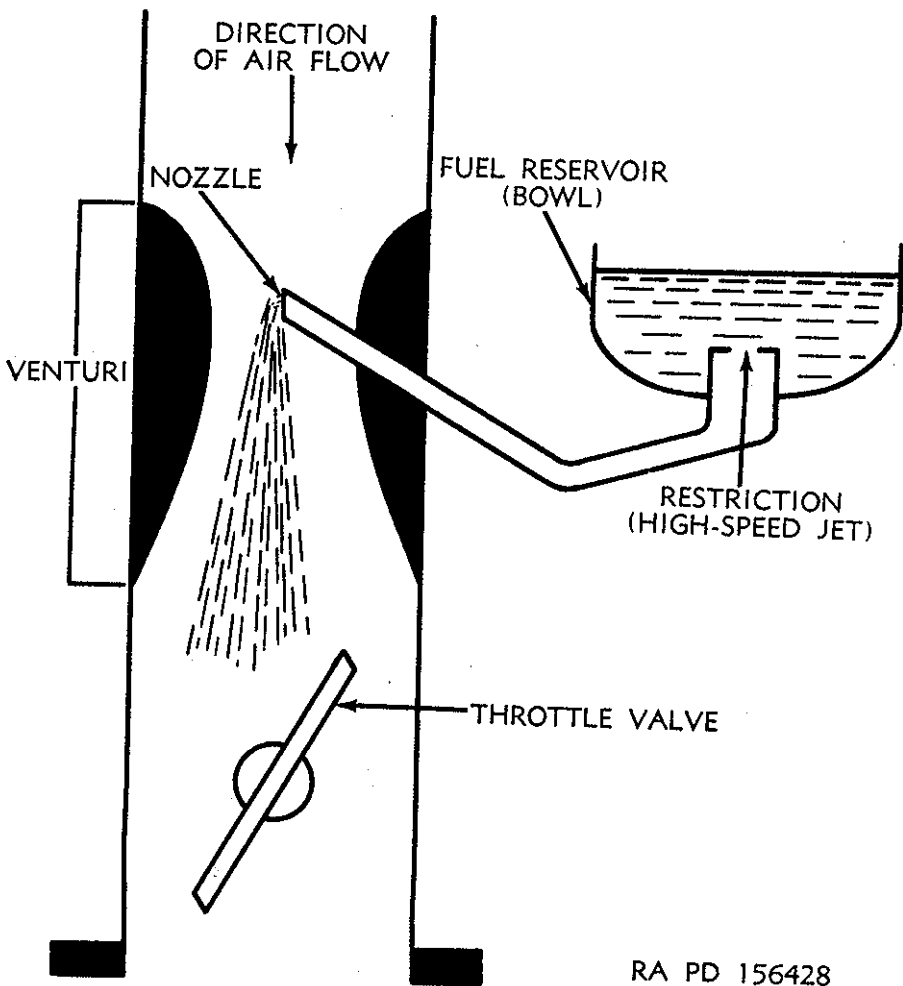

Figure 6. Basic high-speed circuit.

in relation to the carburetors to which they apply. In figure 7 the plain high-speed jet of figure 6 has been enlarged and a "metering rod" inserted into it. The metering rod is a rod with two or three steps machined on its lower end. The effective size of the high-speed jet may be varied by moving the metering rod up or down. The upper end of the rod is connected, by linkage (represented by the dotted lines), to the throttle valve. When the throttle valve is more than three-quarters open (B of fig. 7), corresponding to speeds above 50 mph, the smaller step of the rod is in the jet. This increases the effective size of the jet and permits the greater flow of fuel necessary to enrich the mixture.

## 11. Pump Circuit

*a. Requirements.* When the throttle valve is suddenly opened, in order to accelerate the engine, the flow of air immediately increases; in order to obtain smooth acceleration, without faltering or "holding back," it is necessary that the supply of fuel be increased at the same time so that the required air-fuel ratio will be maintained. Since gasoline is heavier and more viscous than air, the flow from the jets cannot increase as rapidly as the air flow does. It is, therefore, necessary to incorporate some temporary enriching device which will supply an additional quantity of fuel at the same instant that the throttle is opened and maintain this supply until the flow from the high-speed circuit has increased sufficiently.

*b. Operation.* All the carburetors described in this manual use some form of pump to give the additional charge of fuel needed for acceleration. The pump circuit is represented diagrammatically in figure 8. In A of figure 8, the throttle valve, which is mechanically connected to the pump plunger by linkage, represented by the dotted line, is closing. This causes the pump plunger to move up and creates a partial vacuum under the plunger. This vacuum causes the discharge check valve to shut, opens the intake check valve, and draws a supply of fuel from the fuel reservoir, or bowl, into the pump cylinder. In B of figure 8, the throttle valve is opening. This reverses the action of the pump. The plunger moves down and creates a pressure which causes the intake check valve to close, opens the discharge check valve, and forces a charge of fuel into the carburetor. It should be noticed that, as shown here, the pump will stop discharging immediately when the motion of the throttle stops. In a practical carburetor, it is necessary that the discharge be prolonged until the high-speed circuit discharge has caught up with the increase in air flow. Several devices may be used to do this. They are described in the chapters on the carburetors to which they apply. The method of actuating the pump used in this discussion is a mechanical linkage to the throttle valve. The pump

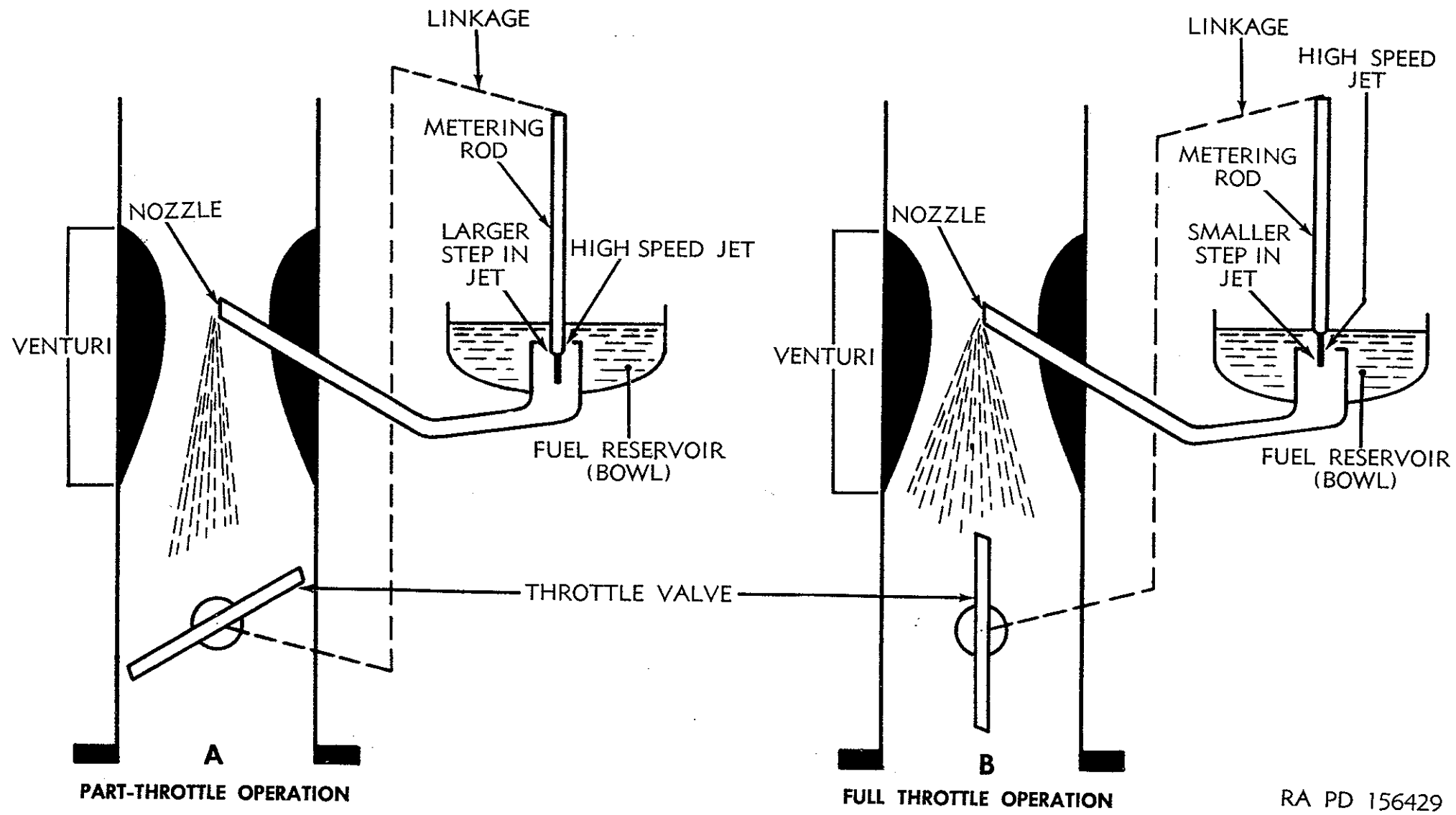
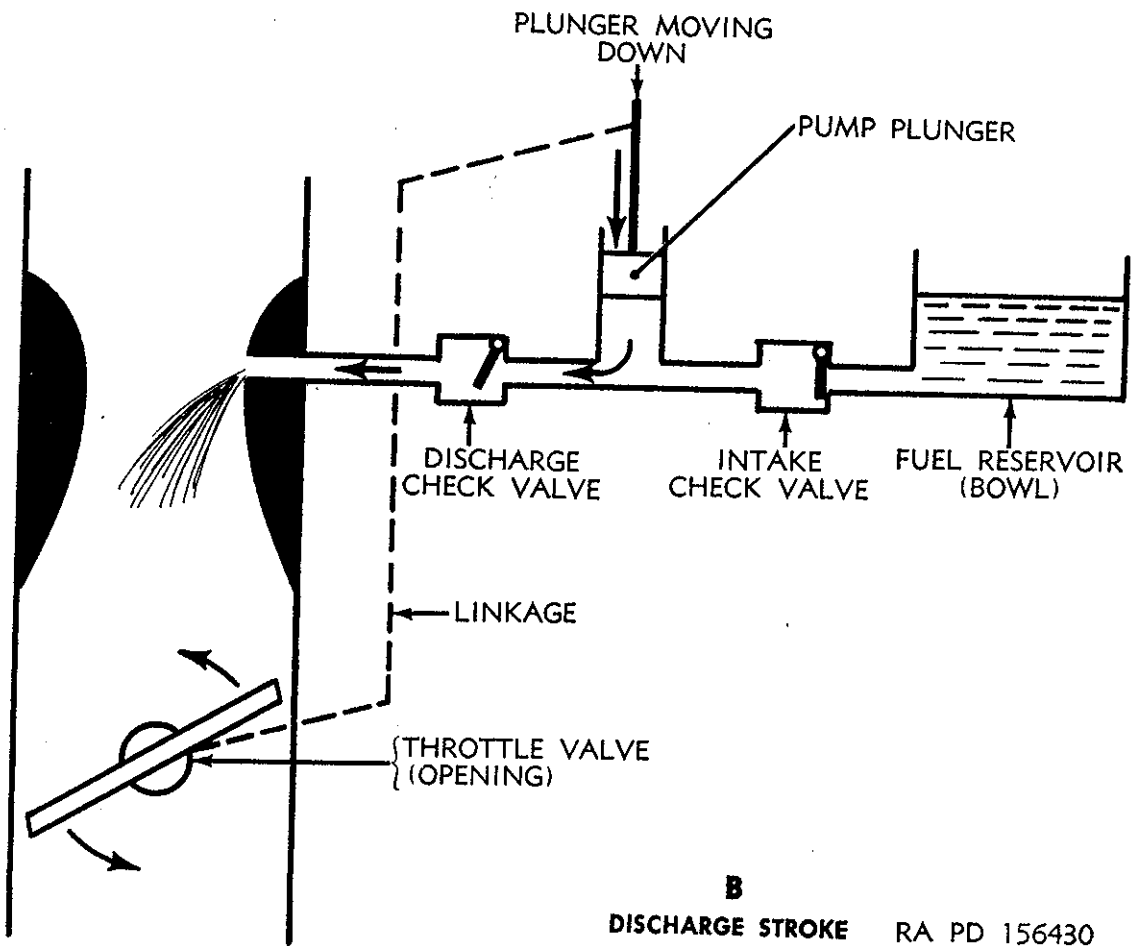
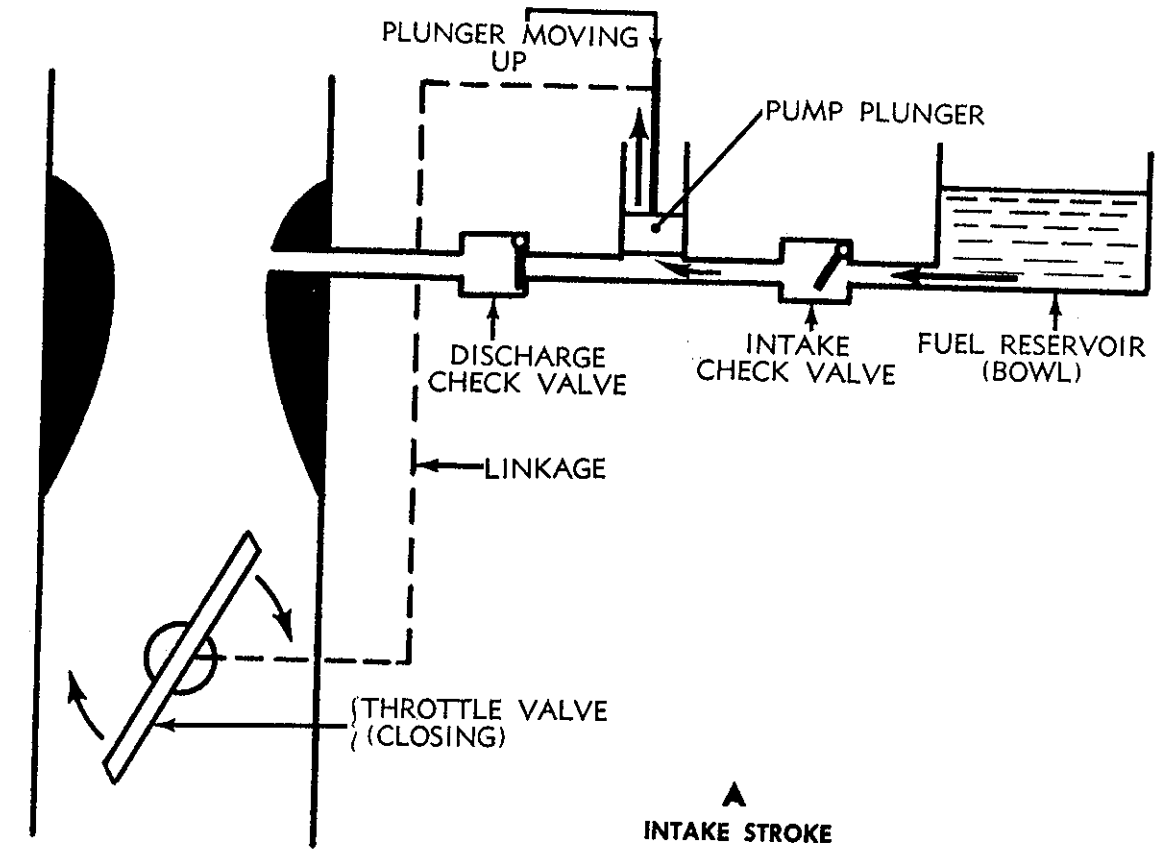

Figure 7. High-speed circuit using metering rod.



RA PD 156430

Figure 8. Operation of pump circuit.

may also be actuated by intake-manifold vacuum. This method of actuation is described further on in the text in the appropriate chapters.

*c. Pump "Bleed" or "Pull-Over."* Figure 9 explains the action known as "pump bleed" or "pump pull-over." The pump jet is usually placed so that it discharges into the throat, or low-pressure area (venturi section), of the carburetor. Thus, since the bowl is exposed to atmospheric pressure, the low-pressure or partial vacuum in the venturi section can cause both the intake and discharge checks to open and thus continuously draw gasoline into the carburetor (A of fig. 9). One type of carburetor described in this manual (type W-O ch. 6) uses this pull-over to supply a portion of the fuel required for constant-throttle operation. However most types use some device to prevent this. One method is shown in B of figure 9. Here the end of the jet is vented to the outside air by means of a drilled passage through the carburetor. Both ends of the pump circuit are then exposed to atmospheric pressure and no flow of fuel can take place. Air will, of course, flow in through the vent, thus preventing pull-over.

## 12. Choke Circuit

*a. Requirements.* The purpose of the choke circuit is to supply a very rich mixture for starting and warming up a cold engine. This is necessary because the fuel in a cold engine cannot be vaporized by the heat of the manifolds and cylinders. Fuel which is not vaporized will not burn readily. Consequently a very rich mixture must be supplied in order that a quantity, sufficient to supply the needs of the engine, will burn. In extremely cold weather, a mixture as rich as 1 : 1 may be used.

*b. Operation.* The choke restricts the air flow into the engine and consequently causes a partial vacuum to be built up, below the choke valve, by the action of the cranked engine. This vacuum draws a considerable quantity of fuel into the engine. The combination of these two actions, the restricted air supply accompanied by a large supply of gasoline, gives the rich mixture required for starting and warm-up.

## 13. Float Circuit

*a. Requirements.* The purpose of the float circuit is to maintain a supply of fuel, at the correct level, in the bowl at all times. It is important that the correct level be maintained because the height of the fuel in the bowl determines the height at which fuel will rest in the nozzle. This in turn will determine the speed at which the high-speed nozzle begins to discharge.

*b. Operation.* The float circuit consists essentially of a float-operated needle valve (needle and seat) and bowl. If the level in

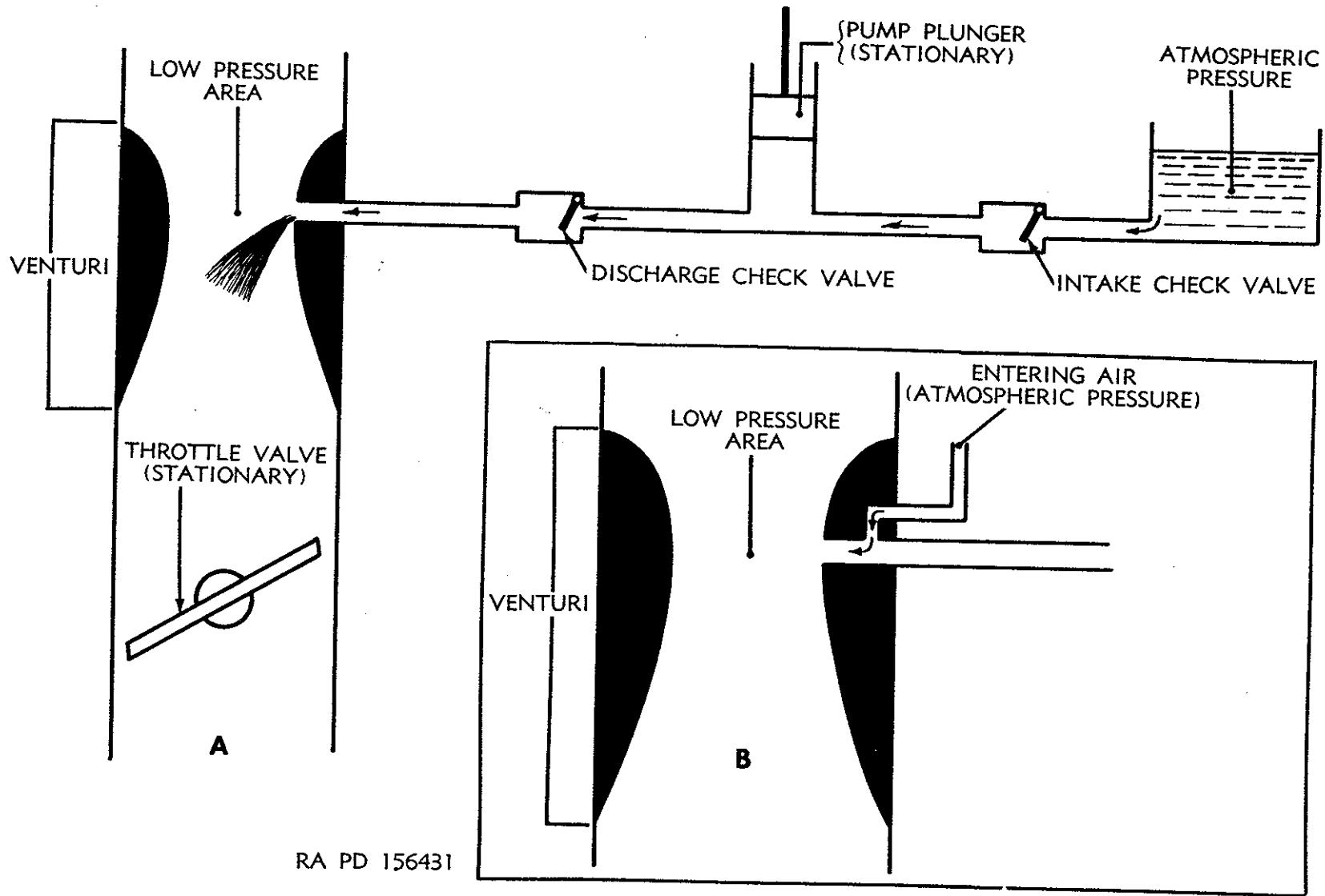

RA PD 156431

Figure 9. Pump bleed.

the bowl is too low, the float drops, opens the needle valve, and permits fuel to be pushed into the bowl by the fuel pump or by gravity if that type of feed is employed. As the fuel level in the bowl rises, the float rises with it until, when the proper level is reached, the needle valve is closed by the float and the flow of fuel is stopped. Since the float must hold the valve closed against the pressure of the fuel pump, it is obvious that if the pressure is too high the level of the gasoline in the bowl will have to be higher in order to exert enough pressure, against the float, to stop the flow of fuel. For this reason the fuel pump pressure must be within specifications in order that the float circuit may function properly.

*c. Bowl Venting.* It is the difference in pressure between the fuel reservoir, or bowl, and the throat of the carburetor that causes the fuel to flow from the jets. In order to maintain this difference in pressure, the fuel bowl must be vented. Two types of bowl vents are in use. The first type, the outside bowl vent, is merely an opening to the outside air drilled into the bowl cover. This type has one fault. Should the air cleaner on the carburetor become clogged, it will act as a choke and decrease the pressure inside the carburetor. This will cause a greater quantity of fuel to flow from the bowl and will give an excessively rich mixture. This difficulty may be overcome by venting the bowl to a point inside the carburetor above the choke valve. In this way any drop in pressure across the air cleaner will be transmitted to the bowl thus maintaining a difference in pressure, between the bowl and the venturi throat, which is proportional to the pressure in the air horn. In this way a constant air-fuel ratio may be maintained. Note that the inside or "balance" vent must be above the choke valve. If it were below the valve, it would be impossible to choke the engine since any drop in pressure below the closed choke valve would be transmitted to the bowl and no fuel could flow.



# CHAPTER 4

## TROUBLE SHOOTING

---

### Section I. GENERAL

#### 18. Purpose

*Note.*—Information in this chapter is for use of ordnance maintenance personnel in conjunction with and as a supplement to the trouble shooting section in the pertinent operator's manual. It provides the continuation of instructions where a remedy in the operator's manual refers to ordnance maintenance personnel for corrective action.

Operation of a defective component may cause further damage. By careful inspection and trouble shooting, such damage can be avoided and, in addition, the causes of faulty operation can then be determined without extensive disassembly.

#### 19. General Instructions

The proper operation of a gasoline engine requires that the engine, the fuel system, and the ignition system must operate properly. If any component is not up to specifications, poor engine performance will result. Similar symptoms may result from defective operation of any of the components. The only way of being sure that a given trouble, such as poor gasoline mileage, or hard starting is being caused by the carburetor is to first check the engine, ignition system, and the fuel system excluding the carburetor. It will also be found that many causes of poor gasoline mileage are the result of bad driving habits or conditions such as excessive use of low speeds in accelerating, sustained high speeds, and stop and start "city" driving.

### Section II. PROCEDURES

#### 20. Trouble Shooting

It is obvious that the best way to trouble shoot a carburetor is while it is mounted on an operating engine. The repairs and adjustments required can best be determined while operating the engine under all conditions. Paragraph 21 lists complaints which may be caused by a defective carburetor.

*Note.*—It should not be assumed that, when these symptoms are present, the fault is always in the carburetor.

See paragraph 19 above for other causes.

## 21. Complaints, Causes, and Remedies

### *a. Poor Gasoline Mileage.*

- (1) *Black smoke from exhaust pipe and sooty deposit on spark plugs caused by rich mixture.*
  - (a) *High float level.* Reset to specifications (tables IV to XI, pars. 28, 44, 61, 78, 95, 109, 124, and 140).
  - (b) *Too large metering jet or a too small metering rod.* Check specifications (tables IV to VIII, pars. 28, 44, 61, 78, and 95). Replace jet or rod.
  - (c) *Nozzle installed without a nozzle gasket, when one is required (par. 33e(8)).* Install gasket.
  - (d) *Metering jet or nozzle loose.* Tighten jet or nozzle plug.
  - (e) *Pump relief port clogged.* Clean port.
  - (f) *Air bleed hole (in air bleed nozzle) stopped up.* Clean nozzle.
  - (g) *Holes in main vent tube clogged.* Install new tube.
  - (h) *High fuel pump pressure.* Repair or replace fuel pump.
  - (i) *Metering rod spring not connected to metering rod.* Connect spring.
  - (j) *Clogged air cleaner (outside vented carburetor).* Clean air cleaner.
  - (k) *Warped bowl cover or damaged bowl cover gasket (inside vented carburetor).* Replace bowl cover or gasket.
  - (l) *Vacuum passage to step-up piston clogged (B-B carburetors).* Clean passage.
  - (m) *Wrong flange gasket used (B-B carburetors).* Refer to paragraph 113d(2).
  - (n) *Flange gasket leaking allowing air to enter vacuum passage to step-up piston (B-B carburetor).* Replace gasket.
  - (o) *Step-up piston stuck in cylinder due to gummy deposits (B-B carburetor).* Clean piston and cylinder.
  - (p) *Two gaskets used under step-up piston, keeping step-up rod from seating (B-B carburetors).* Remove one gasket.
  - (q) *Stretched metering rod spring (Y-S carburetor).* Replace spring.
  - (r) *Worn or ruptured metering rod diaphragm (Y-S carburetor).* Replace diaphragm.
  - (s) *Passage to vacuumeter cylinder blocked (WCD carburetor).* Clean passage.
  - (t) *Vacuumeter piston stuck in cylinder (WCD carburetor).* Clean piston and cylinder.
  - (u) *Choke stuck partially closed.* Centralize choke valve. Repair or replace choke linkage and/or choke control cable. Repair automatic choke if used (par. 77).

(2) *No black smoke from exhaust pipe. White oxide deposit on spark plugs insulators caused by lean mixture.*

(a) *Low float level. Reset to specifications (tables IV to XI, pars. 28, 44, 61, 78, 95, 109, 124, and 140).*

(b) *A too small metering jet or a too large metering rod. Replace with specified rod or jet (tables IV to XI, pars. 28, 44, 61, 78, 95, 109, 124, and 140).*

(c) *Two gaskets used under high speed nozzle where one should be used (par. 33e(8)). Remove one gasket.*

(d) *Restriction in high speed passage. Clean passage.*

(e) *Antipercolator closing too late. Set to specifications (par. 69b).*

(f) *Main vent tube loose (B-B carburetors). Replace tube (pars. 114d and 145e).*

*b. Hard Starting.*

(1) *Hard starting when cold.*

(a) *Choke not closing properly. Repair or replace choke linkage and/or choke control cable. Centralize choke valve. Repair automatic choke if used (par. 77).*

(b) *Bowl being drained. Loose plug in bottom of bowl. Tighten plug.*

(2) *Hard starting when hot.*

(a) *Overchoking. Automatic choke not opening soon enough. Repair choke (pars. 81f and 88a).*

(b) *Antipercolator not opening. Adjust antipercolator (par. 69b).*

*c. Lacks Power.* The same causes that give poor mileage will cause a lack of power. In addition, check the following which may cause poor performance at wide open throttle.

(1) *Vacuumeter not operating (WCD carburetors).*

(a) *Piston stuck in closed position by gummy deposits. Clean piston and cylinder.*

(b) *Spring left out. Install proper spring.*

(2) *Step-up system not operating (B-B carburetors).*

(a) *Step-up piston stuck in closed position by gummy deposits. Clean piston and cylinder.*

(b) *Spring left out. Install correct spring.*

(c) *Step-up rod left out (B-B updraft carburetors). Install rod.*

(d) *Step-up rod installed upside down (B-B updraft carburetor). Install correctly (par. 129c).*

*d. Poor Idle.*

(1) *Engine rolls or gallons caused by a too rich mixture.*

(a) *Carburetor idle improperly adjusted. Adjust idle.*

- (b) *Carbon deposit in bore near idle port.* Remove deposit by scraping or with wet or dry flint paper.
  - (c) *Clogged air bleeds.* Clean bleeds and passages.
  - (d) *Metering hole in low-speed jet or idle orifice tube oversize.* Check against specifications (tables IV TO XI, pars. 28, 44, 61, 78, 95, 109, 124, and 140). Replace parts.
  - (e) *Upper end of low-speed jet not seating (types W-1, W-O, WDO).* Replace jet.
  - (f) *Economizer oversize (see specifications, tables IV to XI, pars. 28, 44, 61, 78, 95, 109, 124, and 140).* Check with shank end of wire drill. Replace casting.
- (2) *Engine misfires (excessive vibration).* This may be caused by a too lean mixture.
- (a) *Carburetor idle adjustment incorrect.* Adjust idle.
  - (b) *Leaking intake manifold gaskets.* Tighten manifold nuts or replace gaskets.
  - (c) *Leaking carburetor flange gasket.* Tighten flange nuts or replace gaskets.
  - (d) *Leaking main body gasket.* Tighten body screws or replace gasket.
  - (e) *Worn throttle shaft bearings.* Replace throttle body.
  - (f) *Economizer clogged.* Clean economizer.
  - (g) *Metering hole in low-speed jet or idle orifice tube clogged.* Clean or replace jet.
  - (h) *Idle port plug loose.* Tighten plug.

*e. Engine Falts or Pops Back Through Carburetor on Acceleration.* This is caused by an insufficient discharge from the pump circuit. It may be checked as follows: with the ignition off, suddenly open the throttle wide while looking into the carburetor. If the pump circuit is operating, the discharge will be seen. If the pump circuit is found to be faulty, investigate the following:

- (1) *Clogged or sticking intake or discharge check valves.* Clean or replace valves.
- (2) *Worn or damaged plunger leather.* Replace plunger.
- (3) *Weak pump spring (B-B and Y-S carburetors).* Replace spring.
- (4) *Ball checks not seating properly (B-B carburetors).* See paragraph 113e(4) for method of diagnosing and eliminating this trouble.
- (5) *Pump passage blocked.* Clean passage.
- (6) *Insufficient pump travel.* Set to specifications (tables IV to VIII, pars. 28, 44, 61, 78, and 95), or if carburetor has "seasonal" pump adjustment, set for long stroke.
- (7) *Vacuum passage clogged (B-B downdraft with governor and Y-S carburetors).* Clean passage.

- (8) *Air leaking into vacuum passage (B-B downdraft with governor and Y-S carburetors).* Tighten flange screws and main body screws or replace gaskets.
- (9) *Pump diaphragm leaking (Y-S carburetor).* Replace diaphragm.

*f. Carburetor Floods or Leaks.*

- (1) *High float level.* Adjust to specifications (tables IV to XI, pars. 28, 44, 61, 78, 95, 109, 124, and 140).
- (2) *Plugged bowl vent.* Clean vent hole with wire.
- (3) *Warped bowl cover or damaged gasket.* Replace bowl cover or gasket.
- (4) *Damaged gasket on needle seat.* Replace gasket.
- (5) *Worn needle and seat.* Replace with new matched pair.
- (6) *Foreign matter between needle and seat.* Clean needle and seat.
- (7) *Ridge worn in lip of float causing float to bind on needle.* Smooth off lip with emery cloth.

**Caution:** Do not file.

- (8) *Cracked bowl.* Replace main body.
- (9) *Float pin worn or holes in float bracket for float pin worn egg-shaped.* Replace float pin and/or float.

*g. Engine Starts and Runs but Will Not Idle.* Check those items listed under *e* above (poor idle).

*h. Engine Starts and Idles but Will Not Run at High Speeds.*

- (1) *High-speed jet, nozzle, or passage blocked.* Clean.
- (2) *High-speed nozzle installed upside down.* Install correctly.
- (3) *Air cleaner blocked.* Clean or replace.
- (4) *Insufficient flow of fuel from fuel pump.* Repair or replace pump.
- (5) *Clogged gasoline filter.* Clean or replace filter.
- (6) *Blocked muffler or tail pipe.* Clean or replace.

*i. "Flat Spot" on Acceleration.* Improperly adjusted or wrong metering rod. Adjust or replace rod.

*j. Engine Stalls While Idling.* This may be caused by an antipercolator which does not open or by flooding (*g* above).

*k. Popping Back Through Carburetor.* This may be caused by an extremely lean mixture (*b*(2) above).

*l. Backfiring.* This may be caused by an excessively rich mixture (*b*(1) above).

## CHAPTER 6

# TYPE W-O CARBURETOR, MODELS 450S, 450SA, 539S, 567S, 572S, AND 698S

---

### Section I. DESCRIPTION AND DATA

#### 38. Description

The type W-O carburetors (fig. 27) are of the outside vented "unbalanced" type. Models 539S, 572S, and 698S differ from the others in that the metering rod seats in the metering rod jet when the throttle is in the normal idling position. This seals off the high speed passage from the float bowl and prevents any discharge of fuel from the high-speed nozzle which might otherwise occur if the engine were operated on a steep incline. This feature also serves as an antipercolator (par. 41b (2)). Descriptions of the low-speed, high-speed, float, pump, and choke circuits are given in paragraphs 39 through 43.

#### 39. Float Circuit

(fig. 28)

The float circuit consists of a needle and seat, float pin, float, and bowl cover gasket. The needle and seat used in these carburetors differs from the conventional type in that the needle is made hollow for a portion of its length and a spring and pin are inserted. When the carburetor is assembled, the lip of the float bears on the spring loaded pin in the needle. This device helps to prevent needle chatter and consequent flooding of the carburetor under conditions of excessive vibration. It is very important that the specified float level be maintained since even a slight deviation will result in unsatisfactory high speed performance.

#### 40. Low-Speed Circuit

(fig. 29)

*a. General.* The low-speed circuit supplies fuel for idle and early part throttle operation. In most carburetors, the fuel must first pass through the main metering jet to get to the low speed circuit. However, this is not the case in the type W-O carburetor. Fuel from the bowl flows directly to the low-speed circuit through the calibrated idle well jet. This feature causes the circuit to be termed "inde-

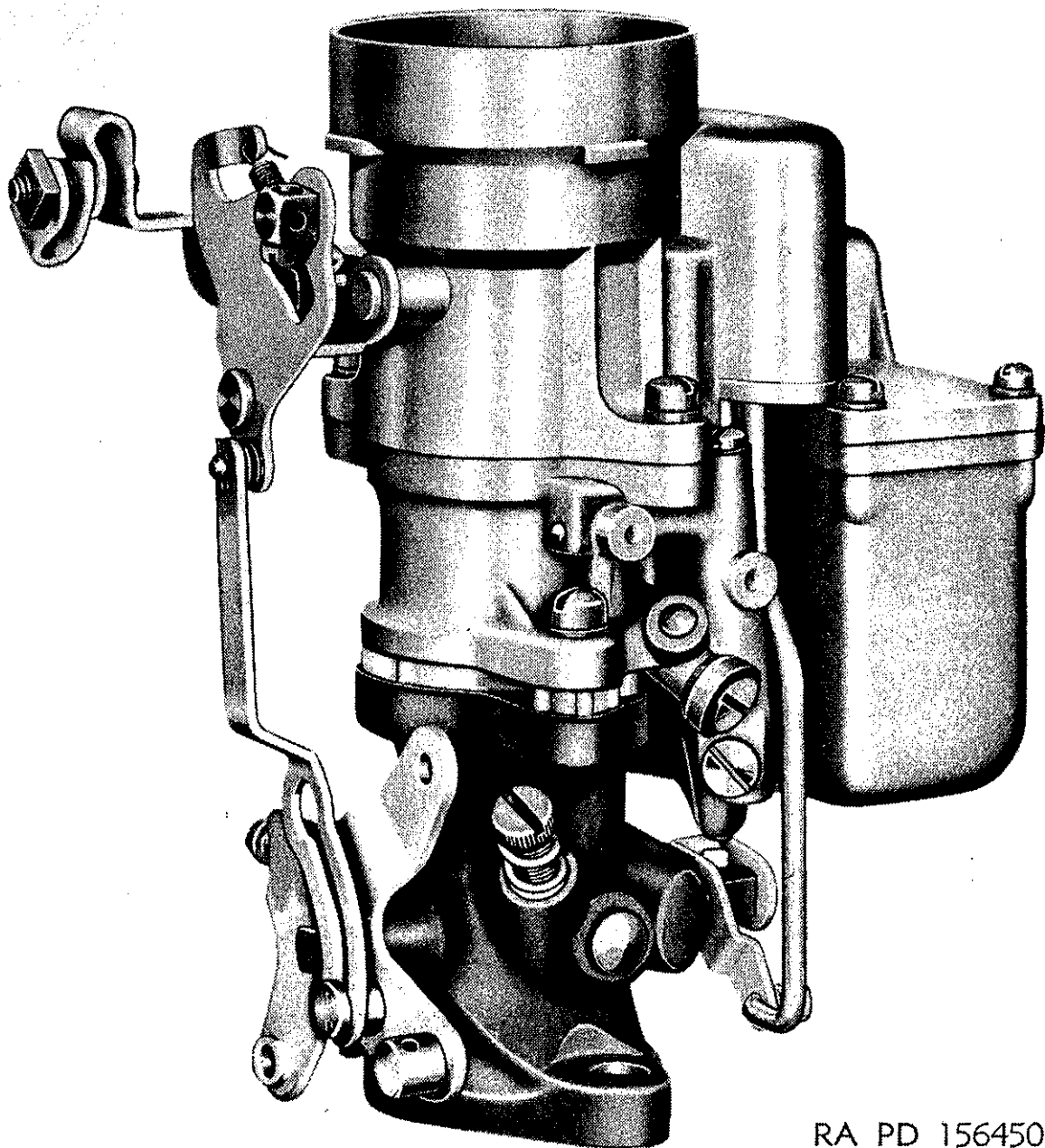

RA PD 156450

*Figure 27. Typical W-O carburetor.*

pendent" or "isolated." Adjacent to the bowl is the idle-well passage in which the low-speed jet is installed. Fuel from the bowl flows through the idle-well jet to the well from which it flows through the calibrated orifice in the low-speed jet and up into the low-speed passage. Here air is admitted from the carburetor throat through the bypass, and the resulting mixture of fuel and air passes through the economizer, which is a restriction in the cross passage. An additional amount of air enters the low-speed passage at this point, through the idle bleed hole, and the mixture flows down the passage terminating at the idle port and idle adjustment screw hole. Most of the fuel is discharged from the idle port. This port is made in the shape of a slot so that as the throttle valve is opened to admit more air it also uncovers a greater portion of the idle port and permits additional gasoline to mix with the air to maintain the necessary air-fuel ratio. It is by this means that a smooth transition is made from the idling

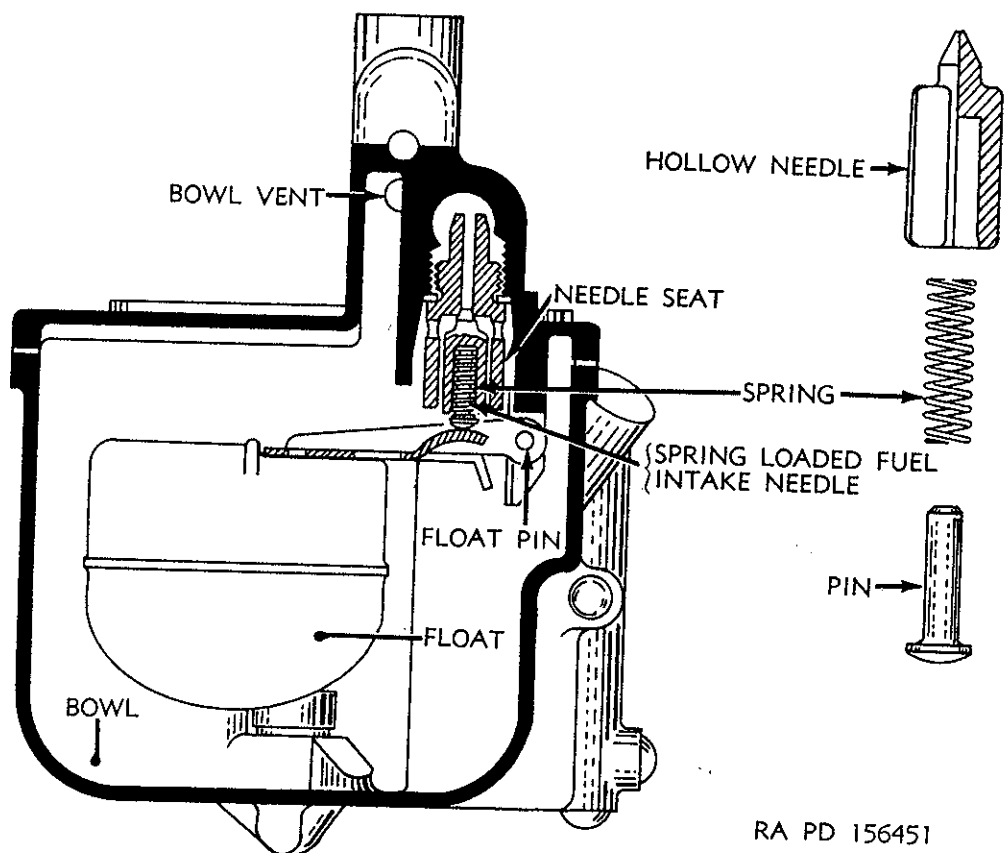

Figure 28. Type W-O carburetor, float circuit.

requirements of the engine. Fuel is admitted through the idle adjustment screw hole. Turning the adjustment screw inwardly (clockwise) decreases the amount of fuel discharged and gives a leaner idle mixture.

*b. Idle-Well Vent (Models 450S and 450SA).* The idle well is vented to the carburetor bowl in the 450S and 450SA carburetors by means of a passage at the top of the well. Gasoline flows from the bowl to the idle well through the idle-well jet by the force of gravity. Thus, when the demands of the idle circuit are greater than the fuel flowing through the idle-well jet, the balance of the demand is met by admitting air through the idle-well vent. This well vent passage is not included in carburetor models 539S, 567S, 572S, and 698S. Consequently, only gasoline is admitted to the low-speed jet.

*c. Idle-Well Jet.* Since there is no connection between the low-speed circuit and the high-speed circuit, the low-speed circuit delivers gasoline throughout the entire range, even at wide open throttle. The purpose of the idle-well jet is two-fold:

- (1) At part throttle and higher speeds, it aids in the metering of the fuel from the low-speed circuit, however, it does not meter the fuel during idle operation.
- (2) On bumpy ground, where the vehicle has extreme side sway, the idle-well jet prevents the gasoline from readily draining out of the idle well, thus assuring constant idle circuit operation regardless of terrain.



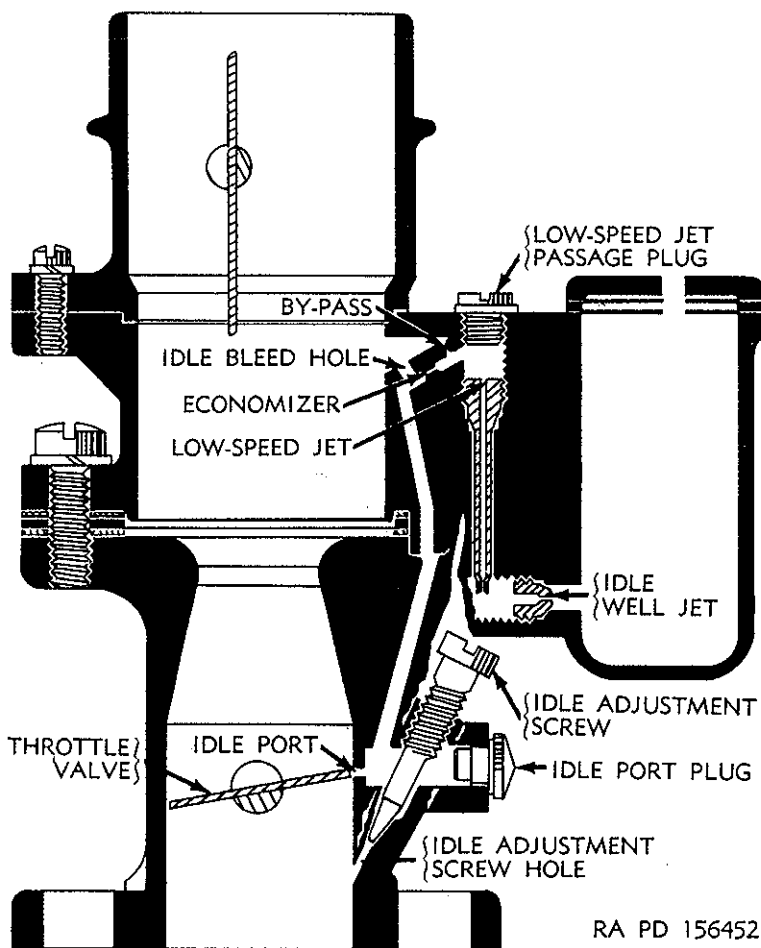

Figure 29. Type W-O carburetor low-speed circuit.

## 41. High-Speed Circuit

(fig. 30)

*a. General.* Fuel from the bowl is metered to the high-speed circuit through the calibrated orifice provided by the metering rod jet and the metering rod within it. From this point, the fuel is conducted through a passage to the nozzle extending into the small venturi. The upper tip of this nozzle is flush with the inner wall of the venturi and the nozzle is, therefore, known as a "flush type" nozzle. When the fuel level in the carburetor bowl is correct, the level of the fuel in the nozzle is just below the lower lip. The metering rod has several steps or tapers machined on the lower end, and as it is raised in the jet it makes the effective size of the fuel orifice greater, thus, permitting more fuel to flow through the circuit to meet the load demand imposed upon the engine. At wide open throttle position, the smallest step of the metering rod is in the circular opening of the jet, thus permitting the maximum amount of fuel to flow through the circuit to meet the requirements of maximum power.

*b. Metering Rod Seat (Models 539S, 572S, and 698S).* On these W-O carburetors, the metering rod seats in the metering rod jet when the throttle is closed (idle position). To insure the seating of the rod in the jet, the metering rod eye is elongated on these models; the

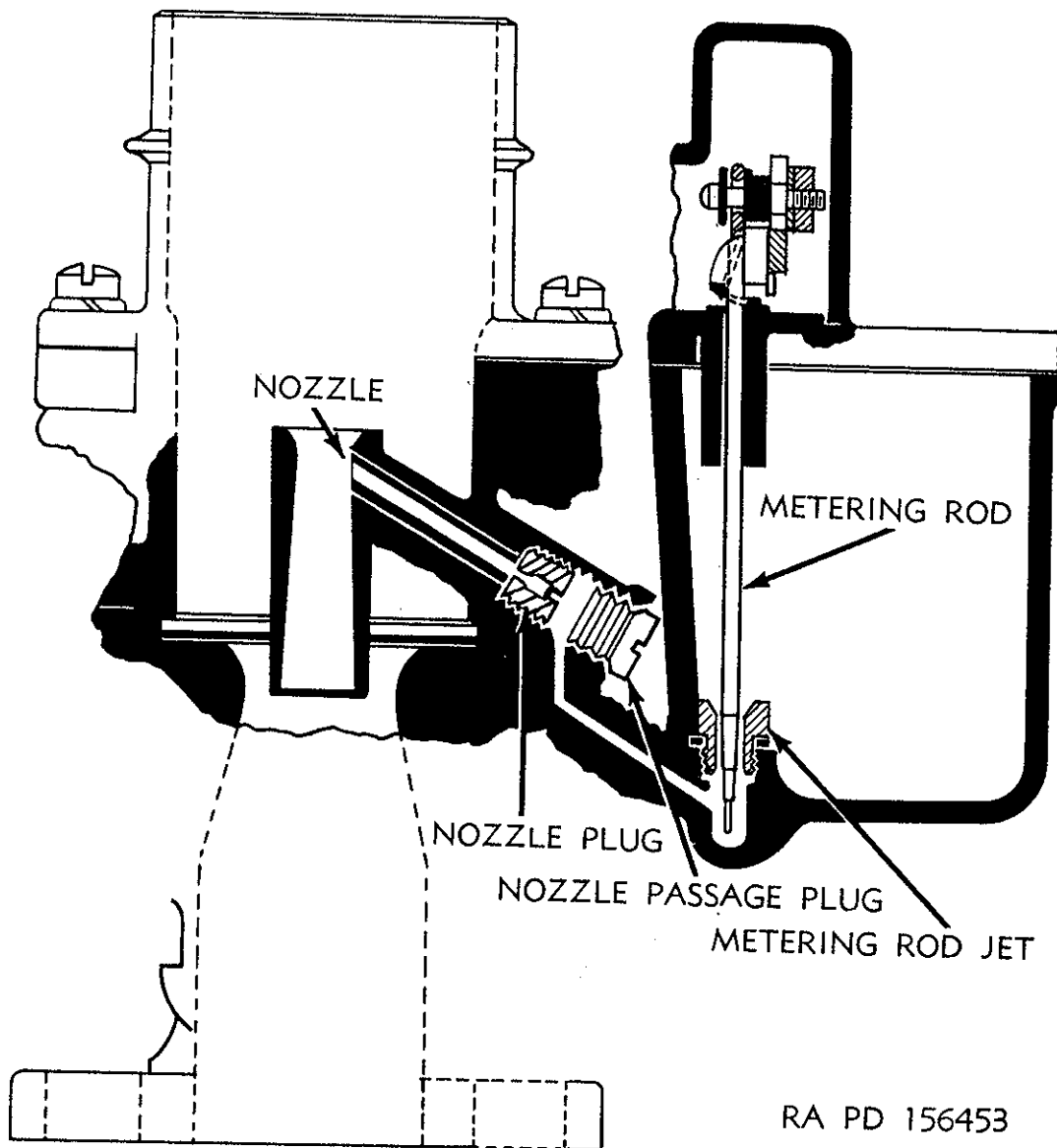

Figure 30. Type W-O carburetor high-speed circuit.

metering rod spring which is hooked through a hole in the rod rather than around it, exerts a downward pressure on the rod. The seating of the metering rod in the jet has two purposes:

- (1) It prevents fuel in the bowl from spilling over the nozzle and stalling the engine when the vehicle is operated at extreme angles on rough terrain.
- (2) It acts as an antipercolator. When a hot engine is idled or stopped the heat of the engine tends to vaporize the fuel in the high-speed nozzle passage. These bubbles of vapor will force fuel out of the nozzle and cause flooding of the engine. This is known as percolation. The seating of the metering rod in the metering jet prevents any large amount of fuel from being forced into the engine by isolating the high-speed circuit from the carburetor bowl.

c. *Adjustable Throttle Stop (Models 567S, and 572S)*. Models 567S and 572S have an adjustable throttle stop on the throttle lever in order to limit the maximum throttle opening.

## 42. Pump Circuit

(fig. 31)

*a. General.* As the throttle is closed, the linkage raises the plunger toward the top of the pump cylinder. On this stroke of the pump, a quantity of fuel from the bowl flows through the intake check valve into the pump cylinder. At this time the discharge check valve is seated preventing air from entering the pump circuit through the pump jet. The check valves are protected from dirt by a strainer located directly beneath them. When the throttle is opened, the plunger is forced downward and the fuel below it is pushed out of the pump cylinder back to the check valve passage. The pressure of the fuel seats the intake check valve ball, preventing the return of the fuel to the bowl. The discharge check valve disk is forced off its seat and the fuel passes through it to the pump jet where it is metered and discharged.

*b. Delayed Action.* It is necessary to provide a delayed action for the discharge of fuel from the pump circuit. This action is achieved in the type W-O carburetors by means of the pump arm spring. This spring connects the pump arm and collar to the pump lever. Therefore, when the throttle is opened, the linkage drives the pump plunger

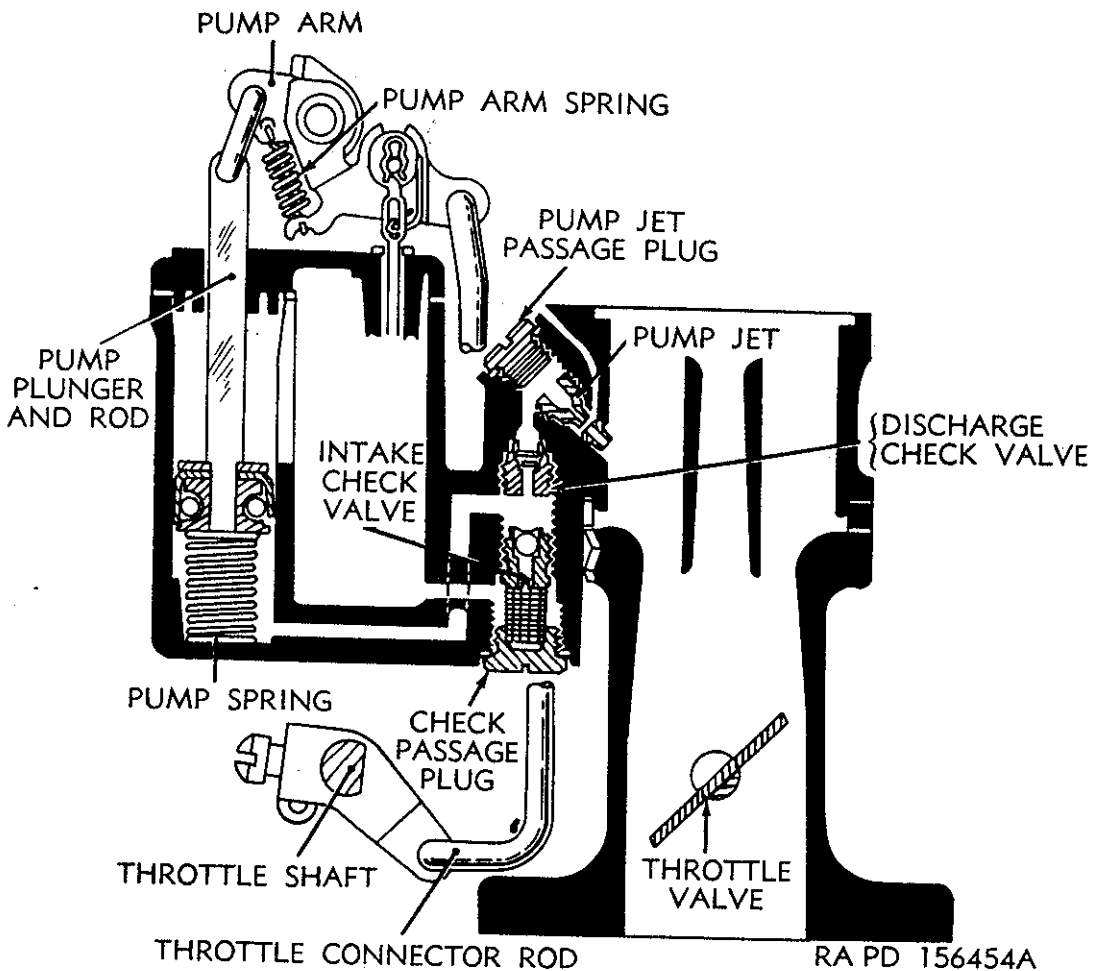

Figure 31. W-O pump circuit.

through the pump arm spring. This provides a continuous discharge from the pump circuit for the necessary time interval.

*c. Pump Jet Relief Hole.* In the pump circuit of these carburetors "pump bleed" is not allowed to occur. "Pump bleed" is the term used to describe the delivery of fuel from the pump jet during constant throttle operation (par. 11c). In the W-O carburetors, the discharge end of the pump jet is extended; both ends of the pump jet have shoulders which seat in the casting. A small hole, from the outside of the casting, vents a cross-drilling between the two seating surfaces in the jet. This vent to the atmosphere destroys the low pressure effect at the pump jet, hence no fuel can bleed from the pump circuit during constant-throttle operation.

### 43. Choke Circuit

(fig. 32.)

*a. General.* These carburetors employ a manual type choke. When the choke is used, the mixture is enriched by cutting down the amount of air admitted through the carburetor and by lowering the pressure in the throat causing a greater amount of fuel to be discharged. These carburetors use a choke valve with a semiautomatic feature, the choke valve plate, which is mounted off center in the air horn, is connected to the operating lever by a soft spring. When the engine starts, the incoming air opens the valve against the tension of the spring. This feature helps prevent over-choking of the carburetor and consequent flooding of the engine. An additional feature, with a function similar to that previously described, is a spring loaded poppet valve incorporated in the choke valve plate (BF', fig. 33). This poppet valve opens when the engine starts, to allow additional inward relief.

*b. Choke Link (Models 450S, 450SA, 539S, and 698S).* These models have a choke link connecting the throttle and choke levers. When the choke valve is closed, this link opens the throttle slightly in order to prevent stalling during the choking period.

### 44. Data

Table V gives the following data for the W-O carburetors: flange number (for model identification); sizes of main venturi, bowl vent, bypass, economizer and idle bleed hole; part numbers of the metering rod, metering rod jet, low-speed jet, repair parts package, and gasket assortment; settings for float level, pump travel, and idle adjustment screw; and numbers of the metering rod and float level gages.

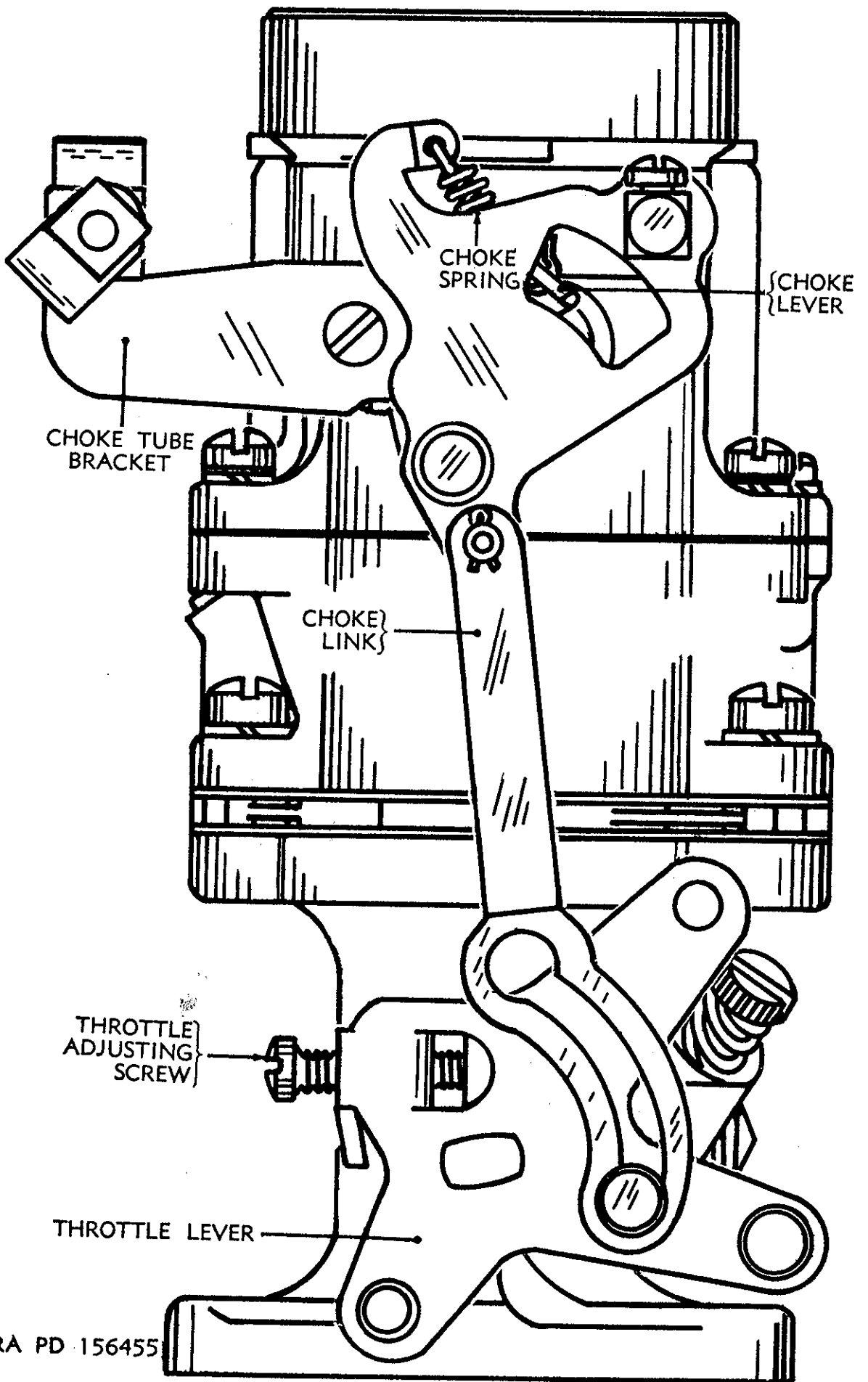

Figure 32. Type W-O carburetor choke circuit.

Table V. W-O Carburetors

Item	W-O Carburetor Models			
	450S 450SA	539S	567S 572S	698S
Flange No. (stamped on manifold side of mounting flange).	"200"-----	"407"-----	"427"-----	"407."-----
Main venturi (diam-in.)-----	1-----	1-----	$\frac{3}{4}$ -----	1-----
Bowl vent (type and drill size) (No.)-----	Outside 10-----	Outside 10-----	Outside 10-----	Outside 10-----
Bypass (diam-in.)-----	0.059 to 0.060-----	0.059 to 0.060-----	0.059 to 0.060-----	0.059 to 0.060-----
Economizer (diam-in.)-----	0.0425 to 0.0435-----	0.0425 to 0.0435-----	0.0425 to 0.0435-----	0.0425 to 0.0435-----
Idle bleed hole (drill size) (No.)-----	52-----	52-----	52-----	52-----
Metering rod-----	CAR-75-390-----	7378112 CAR-75-547-----	CAR-75-570-----	7378112 CAR-75-547-----
Metering rod jet-----	CAR-120-79S-----	7378120 CAR-120-1518-----	CAR-120-135S-----	7378120 CAR-120-151S-----
Low speed jet-----	CAR-11-163S-----	CAR-11-180S-----	CAR-11-180S-----	CAR-1389A-----
Repair parts package-----	CAR-1087B-----	CAR-1319C-----	CAR-1344B-----	7744116 CAR-175A-----
Gasket assortment-----	CAR-147A-----	7744116 CAR-175A-----	7378040 CAR-184-----	7744116 CAR-175A-----
Float level-----	$\frac{3}{8}$ -----	$\frac{3}{8}$ -----	$\frac{3}{8}$ -----	$\frac{3}{8}$ -----
Float level gage-----	41-G-196-25-----	41-G-196-25-----	41-G-196-25-----	41-G-196-25-----
Metering rod gage-----	41-G-234-50-----	41-G-234-50-----	41-G-234-50-----	41-G-234-50-----
Set idle adjustment screw (turns open)-----	$\frac{1}{2}$ to $2\frac{1}{2}$ -----	1 to 2-----	$\frac{1}{2}$ to $2\frac{1}{2}$ -----	1 to 2-----
Pump travel (in.)-----	$\frac{1}{64}$ -----	$\frac{1}{64}$ -----	$\frac{1}{64}$ -----	$\frac{1}{64}$ -----

## Section II. REBUILD OF TYPE W-O CARBURETORS

### 45. General

Due to the close tolerances of carburetor parts (as little as 0.00025 inch for the metering rod and metering rod jet), it is not possible to repair most of the individual parts. The instructions following cover the procedure for completely cleaning and adjusting the carburetor. If the carburetor is to be rebuilt, new parts furnished in repair parts package (table V, par. 44) must be installed. Obviously, if this is done, those parts which are to be replaced need not be cleaned and inspected. When the carburetor is disassembled for any reason, a new gasket assortment (table V, par. 44) should be installed.

### 46. Disassembly

(fig. 33)

#### *a. Remove and Disassemble Air Horn.*

- (1) Remove pin spring (AL), choke link (AS), and choke link spring (AR).
- (2) Remove air horn lock washer screw (BH) and air horn (BE) with all parts attached.
- (3) Remove choke valve plate screws (BG) and choke valve plate (BF).
- (4) Remove choke tube bracket (AV) and choke shaft and lever (AY).

#### *b. Remove and Disassemble Bowl Cover (ZZ).*

- (1) Remove throttle arm screw (F), rod retainer (H), throttle arm (G), and throttle connector rod (J).
- (2) Remove bowl cover lock washer screw (AC) and bowl cover (ZZ) with all parts attached.
- (3) Remove pin spring (AQ), connector link (AP), and plunger and rod (RR).
- (4) Remove metering rod pin nut (AF), metering rod pin washer (AG), metering rod spring (AH), metering rod (AE), metering rod disk (AD), pump arm spring (AM), pump arm and collar (AN), and pump operating lever (AJ).
- (5) Remove float pin (AB), float (SS), fuel intake needle (VV), needle seat (WW), needle seat gasket (XX), and bowl cover gasket (YY).

#### *c. Disassemble Main Body.*

- (1) Remove pump spring (LL).
- (2) Remove low-speed jet passage plug (NN), low-speed jet passage plug gasket (MM), and low-speed jet (FF).
- (3) Remove pump jet passage plug (KK), pump jet passage plug gasket (JJ), and pump jet (HH).

A—THROTTLE VALVE PLATE SCREW	AA—NOZZLE PASSAGE PLUG	AD—METERING ROD DISK
B—THROTTLE VALVE PLATE	BB—IDLE-WELL JET	AE—METERING ROD
C—THROTTLE BODY	CC—IDLE-PASSAGE PLUG GAS- KET	AF—METERING ROD PIN NUT
D—THROTTLE SHAFT AND LEVER	DD—IDLE-PASSAGE PLUG	AG—METERING ROD PIN WASHER
E—THROTTLE ADJUSTING DOG POINT SCREW	EE—MAIN BODY	AH—METERING ROD SPRING
F—THROTTLE ARM SCREW	FF—LOW-SPEED JET	AJ—PUMP OPERATING LEVER
G—THROTTLE ARM	GG—MAIN BODY LOCK WASHER SCREW	AK—METERING ROD PIN
H—ROD RETAINER	HH—PUMP JET	AL—PIN SPRING
J—THROTTLE CONNECTOR ROD	JJ—PUMP JET PASSAGE PLUG GASKET	AM—PUMP ARM SPRING
K—IDLE PORT PLUG	KK—PUMP JET PASSAGE PLUG	AN—PUMP ARM AND COLLAR
L—MAIN BODY GASKET	LL—PUMP SPRING	AP—CONNECTOR LINK
M—INSULATOR	MM—LOW-SPEED JET PASSAGE PLUG GASKET	AQ—PIN SPRING
N—IDLE ADJUSTMENT SCREW SPRING	NN—LOW-SPEED JET PASSAGE PLUG	AR—CHOKE LINK SPRING
P—IDLE ADJUSTMENT SCREW	PP—METERING ROD JET GAS- KET	AS—CHOKE LINK
Q—PIN SPRING	QQ—METERING ROD JET	AT—WIRE CLAMP SCREW
R—CHECK VALVE PASSAGE PLUG	RR—PLUNGER AND ROD	AU—PIN SPRING
S—CHECK VALVE PASSAGE PLUG GASKET	SS—FLOAT	AV—CHOKE TUBE BRACKET
T—STRAINER	TT—NEEDLE PIN	AW—TUBE CLAMP
U—INTAKE CHECK VALVE	UU—NEEDLE SPRING	AX—TUBE CLAMP NUT
V—DISCHARGE CHECK VALVE	VV—FUEL INTAKE NEEDLE	AY—CHOKE SHAFT AND LEVER
W—NOZZLE GASKET	WW—NEEDLE SEAT	AZ—CHOKE SCREW
X—NOZZLE	XX—NEEDLE SEAT GASKET	BC—CHOKE SPRING
Y—NOZZLE RETAINER PLUG	YY—BOWL COVER GASKET	BD—TUBE CLAMP SCREW
Z—NOZZLE PASSAGE PLUG GASKET	ZZ—BOWL COVER	BE—AIR HORN
	AB—FLOAT PIN	BF—CHOKE VALVE PLATE
	AC—BOWL COVER LOCK WASH- ER SCREW	BG—CHOKE VALVE PLATE SCREW
		BH—AIR HORN LOCK WASHER SCREW

Figure 33. Type W-O carburetor, model 698S—exploded view.





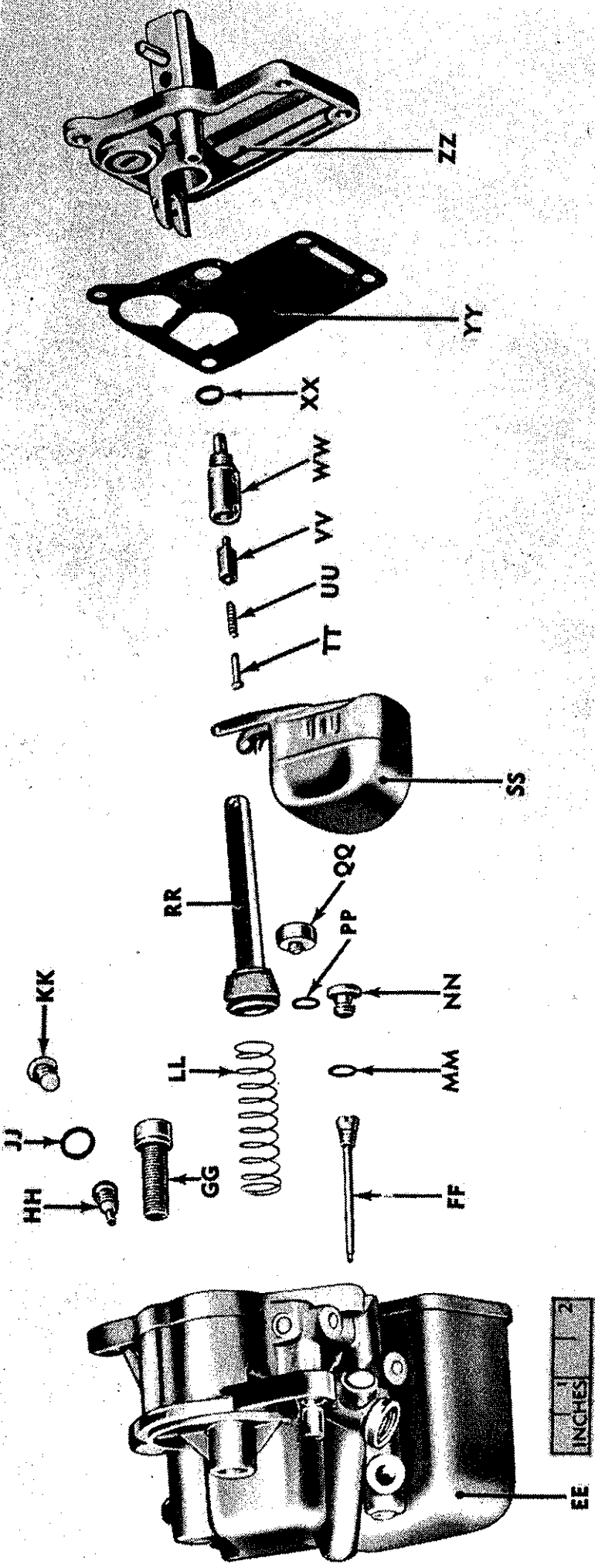

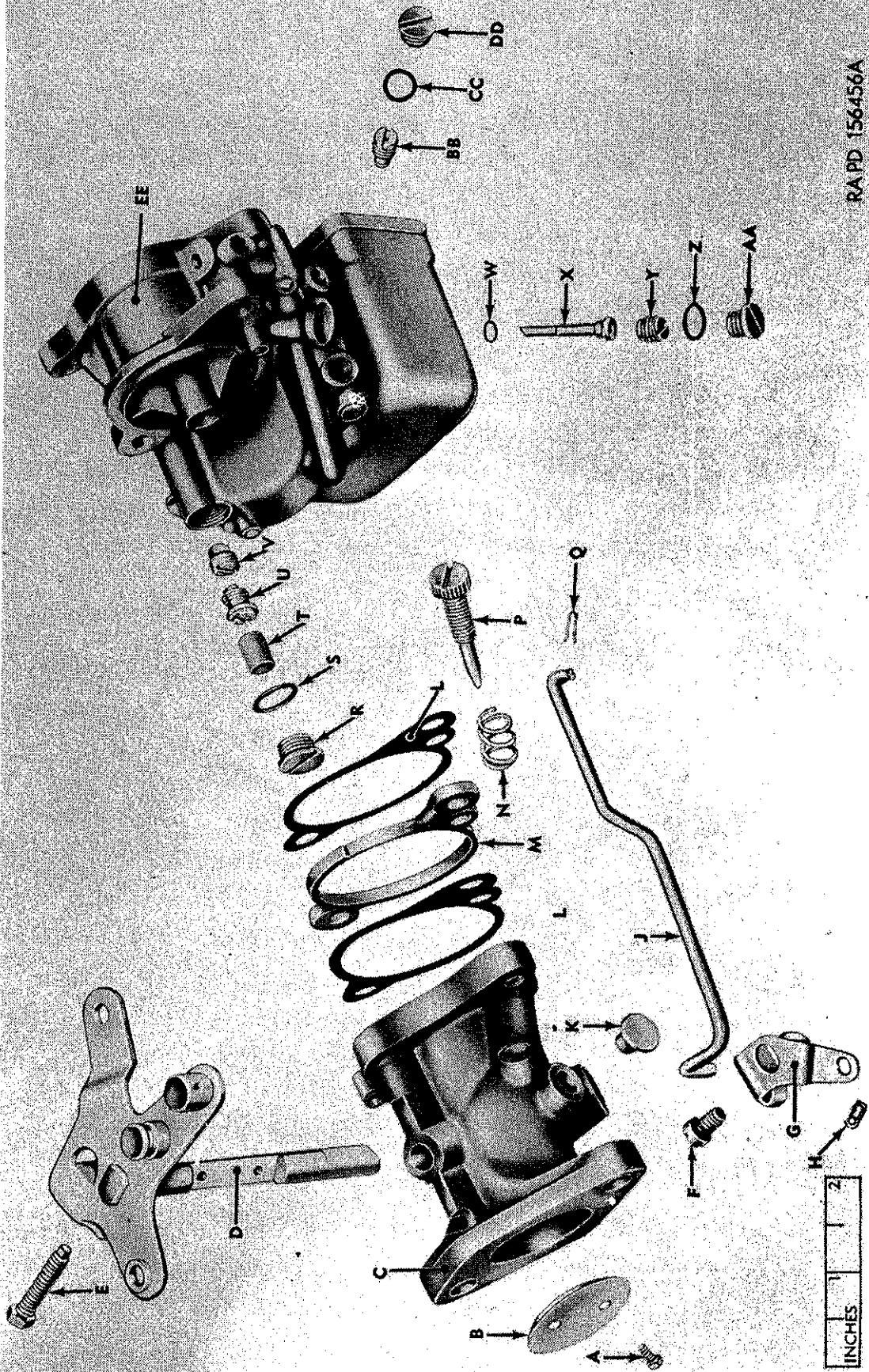

RA PD 156456A



- (4) Remove nozzle passage plug (AA), nozzle passage plug gasket (Z), nozzle retainer plug (Y), nozzle (X), and nozzle gasket (W). Use puller 41-P-2951-10 (fig. 18) to remove nozzle.
- (5) Remove metering rod jet (QQ) and metering rod jet gasket (PP).
- (6) Remove check valve passage plug (R), check valve passage plug gasket (S), strainer (T), intake check valve (U), and discharge check valve (V).
- (7) Remove idler passage plug (DD), idler passage plug gasket (CC), and idle well jet (BB).

*d. Remove and Disassemble Throttle Body (C).*

- (1) Disassemble throttle body (C) from main body (EE) and remove insulator (M) and main body gaskets (L).
- (2) Remove throttle valve plate screws (A), throttle valve plate (B), and throttle shaft and lever (D).
- (3) Remove idle adjustment screw (P), idle adjustment screw spring (N), idle port plug (K), fuel intake needle (VV), needle spring (UU), and needle pin (TT).

## 47. Cleaning

Soak all parts in dry-cleaning solvent or volatile mineral spirits for at least 20 minutes. (The use of a wire basket for the small parts will facilitate their handling.) Blow out all castings with compressed air. Blow out all passages by applying the tip of the blow gun directly to the opening of the passages. Remove any carbon accumulation from the bore of the throttle body by scraping or with wet or dry flint paper.

**Caution:** Do not use emery cloth.

Blow out all jets, nozzles, and check valves. By either blowing or visual inspection, see that all openings in jets and nozzles are clear and that check valves are undamaged.

## 48. Inspection and Repair

(fig. 33)

*a. Bowl Cover, Air Horn, Throttle Body and Main Body.*

- (1) Check bowl cover (ZZ) for warpage and wear on counter-shaft pin. Replace cover if warped or worn.
- (2) Check air horn (BE) for out of roundness and wear in choke shaft bearings. Replace if defective.
- (3) Inspect throttle body (C) for wear on throttle shaft bearings. Replace if worn.

- (4) Be sure that the old nozzle gasket (W) has been removed from the high-speed passage.
- (5) Be sure that all passages are clear of carbon and dirt.
- (6) Check all shoulders for seats of check valves, low-speed jet (FF), idle well jet (BB) and pump jet (HH) to see that they are not damaged.
- (7) If bottom of float bowl in main body (EE) shows oxidation, remove all deposit with a wire brush and paint inside of bowl with a good grade of auto body lacquer.

*b. Float Circuit.*

- (1) Check fuel intake needle and needle seat (VV and WW) for wear (par. 32b.(1)). Replace if worn.
- (2) Check float (SS) for loading damage and wear. If lip of float is worn it may be smoothed with fine emery cloth.

*Note.*—Do not file.

Replace float if damaged or loaded.

*c. Low-Speed Circuit.*

- (1) Inspect low-speed jet (FF) and idle well jet (BB) for damage or obstructions. Replace if damaged.
- (2) Inspect idle adjustment screw (P) for wear or damage. Replace if necessary.

*d. High-Speed Circuits.*

- (1) Inspect metering rod (AE) and metering rod jet (QQ) for wear. Replace if worn.
- (2) Inspect nozzle (X), nozzle retainer plug (Y), and nozzle passage plug (AA) for damage. Replace if necessary. (Note particularly the seating surfaces.) Be sure that the old nozzle gasket (W) is removed from the nozzle.
- (3) Inspect throttle connector rod (J) and throttle arm (G) for wear. Replace if worn.

*e. Pump Circuit.*

- (1) Inspect plunger and rod (RR) for wear or damage to the leather. Replace if necessary.
- (2) Inspect intake check valve (U) and discharge check valve (V) for proper operation and for damage to the seating surfaces. Inspect pump jet (HH) for damage to seating surfaces. Replace if necessary.
- (3) Inspect connector link (AP) and hole in pump operating lever (AJ) for wear. Replace link or shaft and lever if worn.

*f. Choke Circuit.* See that choke spring (BC) is not stretched or weak. Replace if necessary.

## 49. Assembly

(fig. 33)

### a. Group Parts.

*Note.*—Parts for the five circuits listed in (1) through (5) below when grouped as directed will greatly facilitate assembly of the carburetor.

- (1) Group float circuit parts including bowl cover gasket (YY), fuel intake needle (VV), needle seat (WW), needle seat gasket (XX), needle spring (UU), needle pin (TT), float (SS), and float pin (AB).
- (2) Group low-speed circuit parts including throttle shaft and lever (D), throttle valve plate (B), throttle valve plate screws (A), idle adjustment screw (P), idle adjustment screw spring (N), idle port plug (K), insulator (M), main body gaskets (L), idle well jet (BB), idle passage plug (DD), idle passage plug gasket (CC), low-speed jet (FF), low-speed jet passage plug (NN) and low-speed jet passage plug gasket (MM).
- (3) Group high-speed circuit parts including throttle arm (G), throttle connector rod (J), nozzle (X), nozzle passage plug gasket (Z), nozzle retainer plug (Y), nozzle passage plug (AA), and nozzle passage plug gasket (Z).
- (4) Group pump circuit parts including pump jet (HH), pump jet passage plug (KK), pump jet passage plug gasket (JJ), discharge check valve (V), intake check valve (U), strainer (T), check valve passage plug (R), check valve passage plug gasket (S), pump spring (LL), plunger and rod (RR), pump arm and collar (AN), pump arm spring (AM), pump operating lever (AJ), and connector link (AP).
- (5) Group choke circuit parts including choke shaft and lever (AY), choke valve plate (BF), choke valve plate screws (BG), choke link (AS), choke link spring (AR), and pin spring (AU).

### b. Install Float Circuit Parts.

- (1) Install bowl cover gasket (YY), needle seat (WW), needle seat gasket (XX), needle, needle spring, and pin.
- (2) Install float (SS) and float pin (AB).

### c. Install Pump Circuit Parts.

- (1) Install pump jet (HH), pump jet passage plug (KK), and pump jet passage plug gasket (JJ).
- (2) Install discharge check valve (V) and intake check valve (U).
- (3) Push strainer (T) into recess in check valve passage plug (R) and install strainer (T), check valve passage plug (R), and check valve passage plug gasket (S) as assembled.
- (4) Install pump spring (LL) and plunger and rod (RR).

*d. Assemble Low-Speed Circuit.*

- (1) Install throttle shaft and lever (D) and throttle valve plate (B). Install valve with "O" trademark toward idle port and facing manifold. Insert throttle valve plate screws (A) loosely. Close throttle and tap valve lightly to centralize the plate in the bore. Hold in place and tighten screws.
- (2) Install idle adjustment screw (P) and idle adjustment screw spring (N) and set to specifications (table V, par. 44).
- (3) Install new idle port plug (K).
- (4) Assemble throttle body (C) to main body (EE). Place a new main body gasket (L) above and below insulator. Be sure that the holes are alined. Aline insulator (M) and main body gaskets (L) with throttle body and main body. Insert screws main body lock washer (GG) and tighten.
- (5) Install idle well jet (BB), idle passage plug (DD) and idle passage plug gasket (CC).
- (6) Install low-speed jet (FF), low-speed jet passage plug (NN), and low-speed passage plug gasket (MM).

*e. Install High-Speed Circuit Parts.*

- (1) Install bowl cover (ZZ) as assembled. Tighten bowl cover lock washer screws (AC) evenly.
- (2) Install pump arm and collar (AN) and pump operating lever (AJ).
- (3) Install connector link (AP) with pin spring (AL) at top and away from bore.
- (4) Install throttle arm (G) and throttle connector rod (J), secure with rod retainer (H).
- (5) Install nozzle (X) and new nozzle gasket (W). Have flat side of nozzle facing up.
- (6) Install nozzle retainer plug (Y), nozzle passage plug (AA), and nozzle passage plug gasket (Z).
- (7) Adjust pump stroke and metering rod (pars. 52 and 53).
- (8) Install metering rod (AE) and metering rod disk (AD). On models 539S, 572S, and 698S, the metering rod spring is inserted through the hole in the metering rod. The spring should exert a downward pressure on the rod when it is seated. If it does not, bend it slightly to accomplish this.

*f. Assemble Choke Circuit.*

- (1) Install choke shaft and lever (AY) and choke valve plate (BF). Centralize valve by tapping lightly against bore before tightening choke valve plate screws (BG).
- (2) Assemble air horn (BE) to body with air horn lock washer screw (BH).

- (3) Install choke tube bracket (AV) with choke screw (AZ).
- (4) Install connector link (AP), choke link spring (AR), and pin spring (AQ).
- (5) Adjust fast idle (par. 54).

### Section III. ADJUSTMENT OF TYPE W-O CARBURETORS

#### 50. General

Whenever a W-O carburetor is repaired, the float level, pump stroke metering rod, and fast idle should be adjusted. The methods of adjusting these for the W-O carburetors are given in paragraphs 51, 52, 53, and 54. Specifications are given in table V (par. 44).

#### 51. Float Level Adjustment

Swing gasket aside so that float level gage may be placed on machined surface of bowl cover. Adjust float level to specifications (table V, par. 44) by bending lip of float until float just touches gage.

*Note.*—Due to the use of the spring and pin in the needle of this model carburetor, the float must be kept level and be allowed to rest on needle by its own weight only or a correct adjustment will not be obtained.

#### 52. Pump Stroke Adjustment

(fig. 34)

*a.* Back out throttle adjustment screw and hold throttle in fully closed position.

*b.* Place base of gage 41-G-256 on raised portion of bowl cover with notch against plunger rod.

*c.* Turn knurled nut on gage until projecting finger rests on top of plunger rod.

*d.* Remove gage and note figure closest to index mark on beveled edge of knurled nut.

*e.* Open throttle wide and repeat *c* and *d* above.

*f.* Subtract wide open throttle reading from closed throttle reading. The difference is pump stroke in sixty-fourths of an inch.

*Note.*—A tolerance of plus or minus one-sixty-fourth of an inch from specified plunger stroke (table V, par. 44) is permitted. Adjust stroke by bending throttle connector rod at lower angle next to throttle arm (fig. 34). To increase pump stroke, bend throttle connector rod to raise starting position of plunger. To decrease pump stroke, bend throttle connector rod to lower the starting position of plunger.

**Caution:** Pump must be adjusted before metering rod is adjusted.



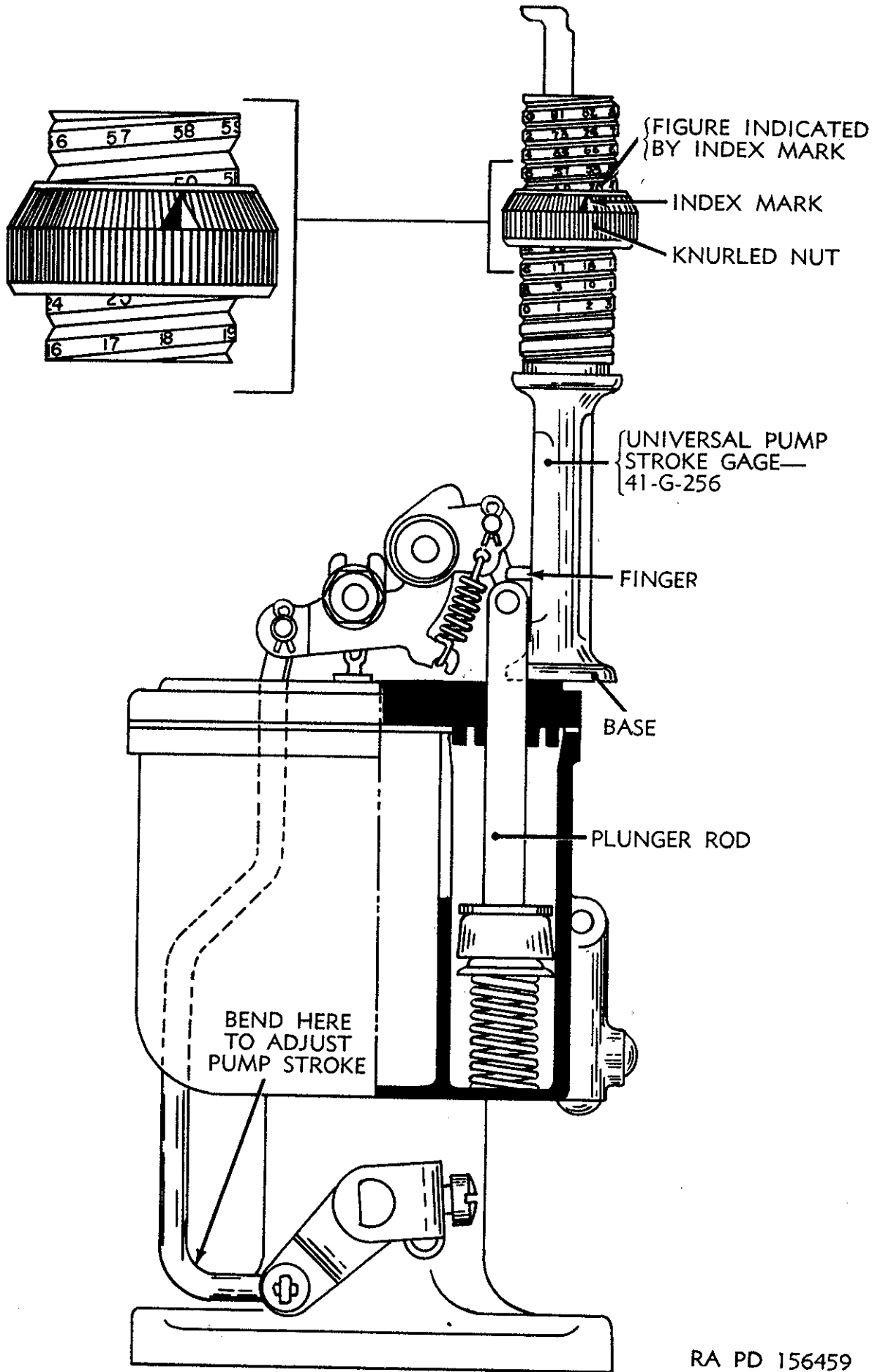

Figure 34. Gaging pump stroke with gage 41-G-256.

RA PD 156459

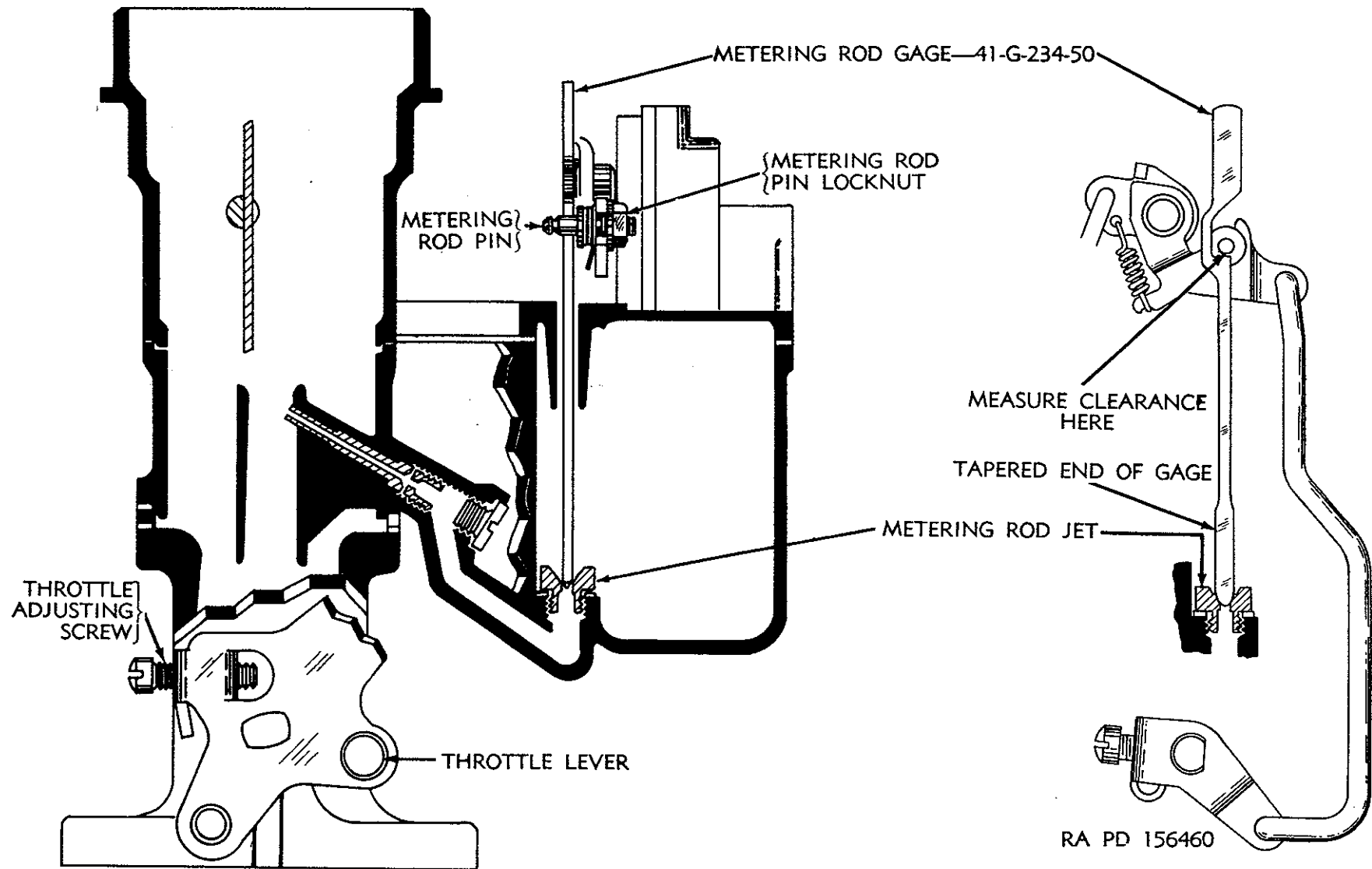

Figure 35. Gaging metering rod.

### **53. Metering Rod Adjustment**

*a.* See CAUTION in paragraph 52. Back out throttle adjusting screw and hold throttle valve fully closed.

*b.* Insert metering rod gage 41-G-196-50 (table V, par. 44), in place of metering rod, with tapered end seated in metering rod jet (fig. 35). Metering rod pin on arm should be free but there should be less than 0.005-inch clearance between the metering rod pin and shoulder of gage, adjust if necessary, using wrench to loosen or tighten metering rod pin lock nut.

*c.* Remove gage and install metering rod and disk. Replace metering rod spring.

### **54. Fast Idle Adjustment (Carburetor Models 539S, 450S, 450SA, and 698S)**

Close throttle valve and move choke to closed position. Throttle should be pulled open 0.080 to 0.090 inch (distance between throttle valve and bore of carburetor at side opposite idle port). Adjust by bending choke link (fig. 32) at offset portion.

*Note.*—Be sure that bending is done at the offset and that the ends of the link are parallel, so that no binding occurs at either end.